

PMR Panel Mount Power Supply

PMR 1K0W series / PMR-□V1K0W1BT

PMR

Highlights & Features

- Built-in active PFC and conforms to harmonic current IEC/EN 61000-3-2, Class A
- Active Current Sharing Up to 4 units in parallel
- Built-in Remote ON/OFF and Remote Sense
- Compact 1U low-profile design
- Terminal block cover and conformal coating available
- Certified for industrial and household applications (IEC/EN 62368-1, 60335-1, 61558-1, 61558-2-16)
- Over voltage category III (OVC III)
- Wide operating temp -40°C ~70°C

Safety Standards



CB Certified for worldwide use

Model Number: PMR-□V1K0W1BT
Unit Weight: 1.45 kg (3.2 lb)
Dimensions (L x W x H): 225 x 124 x 41 mm (8.86 x 4.88 x 1.61 inch)

General Description

PMR Series 1000 W power supply offers the nominal output voltage of 12 V/24 V/36 V/48 V across a wide operating temperature range from -40°C to +70°C and obtains shock and vibration certification IEC 60068-2. The PMR series is made for installation in limited spaces. Its built-in active PFC circuit provides high power factor values and conforms to harmonic current emission standards IEC/EN 61000-3-2, Class A. It also equips active current sharing function; power supply can be used in parallel up to 4 units.

Model Information

PMR Panel Mount Power Supply

Model Number	Input Voltage Range	Rated Output Voltage	Rated Output Current
PMR-12V1K0W1BT	90-264 Vac (127-375 Vdc)	12 Vdc	60.00 A
PMR-24V1K0W1BT		24 Vdc	42.00 A
PMR-36V1K0W1BT		36 Vdc	28.00 A
PMR-48V1K0W1BT		48 Vdc	21.00 A

Model Numbering

PM	R –	□V	1K0W	1	B	T
Panel Mount	Product Type R – Standard Rack Type Series (1U)	Output Voltage 12 – 12 V 24 – 24 V 36 – 36 V 48 – 48 V	Output Power*1	Single Phase	Family Code: B	Connector Type T – Terminal Block

*1 For 12V model, output power is 720W.

PMR Panel Mount Power Supply

PMR 1K0W series / PMR-□V1K0W1BT

Specifications

Model Number	PMR-12V1K0W1BT	PMR-24V1K0W1BT	PMR-36V1K0W1BT	PMR-48V1K0W1BT
--------------	----------------	----------------	----------------	----------------

Input Ratings / Characteristics

Nominal Input Voltage	100-240 Vac			
Input Voltage Range	90-264 Vac			
Nominal Input Frequency	50-60 Hz			
Input Frequency Range	47-63 Hz			
DC Input Voltage Range* ²	127-375 Vdc			
Input Current	7.5 A typ. @ 115 Vac, 3.5 A typ. @ 230 Vac (For 12V model) 10.1 A typ. @ 115 Vac, 5.0 A typ. @ 230 Vac (For others model)			
Efficiency at 100% Load @ 230Vac	90.0% typ.	93.0% typ.	93.0% typ.	93.0% typ.
No Load Power Consumption @ 230 Vac	2.5W typ.		3.5W typ.	
Max Inrush Current (Cold Start)	45 A typ. @ 230 Vac			
Power Factor at 100% Load	> 0.96 @ 115 Vac & 230 Vac			
Leakage Current	< 2.0 mA typ. @ 240 Vac			

*2 Power Supply can operate at DC Input voltage, please connect +pole to L, -pole to N and PE terminal to an earth wire or to the machine ground.

Output Ratings / Characteristics*³

Nominal Output Voltage	12 Vdc	24 Vdc	36 Vdc	48 Vdc
Total Regulation	12 Vdc ± 1%	24 Vdc ± 1%	36 Vdc ± 1%	48 Vdc ± 1%
Output Voltage Adjustment Range	10.8-13.2 Vdc	24-28 Vdc	32.4-39.6 Vdc	48-55 Vdc
Output Current	0-60.0 A	0-42.0 A	0-28.0 A	0-21.0 A
Output Power	720.0W Max.	1008.0W Max.	1008.0W Max.	1008.0W Max.
Line Regulation	± 0.5% typ. @ 115 Vac & 230 Vac			
Load Regulation	± 1.0% typ.	± 0.5% typ.		
PARD* ⁴ (20 MHz)	< 150 mVpp @ 0°C to 70°C 450 mVpp typ. @ -30°C to 0°C	< 200 mVpp @ 0°C to 70°C 600 mVpp typ. @ -30°C to 0°C	< 250 mVpp @ 0°C to 70°C 750 mVpp typ. @ -30°C to 0°C	
Rise Time	50 ms typ. @ 115 Vac & 230 Vac			
Start-up Time	500 ms typ. @ 115 Vac & 230 Vac			
Hold-up Time	16 ms typ. @ 115 Vac & 230 Vac			
Dynamic Response (Overshoot & Undershoot O/P Voltage)	± 10% @ 115 & 230 Vac input, 10-100% load (Slew Rate: 2.5 A/μS, 50% duty cycle @ 5 Hz & 10 KHz)			
Start-up with Capacitive Loads	8000 uF Max	8000 uF Max	6000 uF Max	5000 uF Max

*3 For power de-rating from > 50°C to 70°C, see power de-rating on page 3.

*4 PARD is measured with an AC coupling mode, and in parallel to end terminal with 0.1μF ceramic capacitor & 47μF electrolytic capacitor. PSU need to burn in > 5 minutes when AMB ≤ 0°C

PMR Panel Mount Power Supply

PMR 1K0W series / PMR-□V1K0W1BT

Mechanical

Case Chassis	SGCC	
Case Cover	SGCC	
Dimensions (L x W x H)	225 x 124 x 41 mm (8.86 x 4.88 x 1.61 inch)	
Unit Weight	1.45 kg (3.2 lb)	
Indicator	Green LED (DC OK)	
Cooling System	Force Cooling	
Terminal	Input & Output	M3.5 x 9 Pins (Rated 300 V / 20 A)
	CN400	Signal Connector: CVILUX CP3506P1H00-NH Mating connector: CVILUX CP3506S0010 or equivalent
Wire	AWG 14-10 Current rating can refer to page 6 "Wire AWG Table"	

Environment

Surrounding Air Temperature	Operating	-40°C to +70°C
	Storage	-40°C to +85°C
Power De-rating	> 50°C de-rate power by 2% / °C < 100Vac de-rate power by 1% / V (90% load @ 90 Vac)	
Operating Humidity	20 to 90% (Non-Condensing)	
Operating Altitude	0 to 5,000 Meters (0 to 16,400 ft)	
Shock Test	Non-Operating	IEC 60068-2-27, Half Sine Wave: 50 G for duration of 11 ms; 3 times per direction
Vibration	Operating	IEC 60068-2-6, Sine Wave: 10 Hz to 500 Hz @ 2G ; 10 min per cycle, 60 min for each axis (X,Y,Z)
Over Voltage Category	II (Meet EN 62477-1 OVC III with 2000 meters altitude)	
Pollution Degree	3	
Acoustic Noise*4	10% load, 25°C	40 dB
	80% load, 25°C	50 dB

*4 Acoustic Noise test set up according to ISO-7779

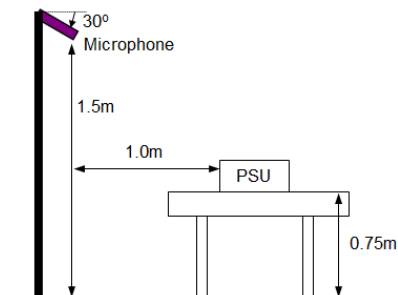

Figure 3-1. Acoustic noise testing set up

PMR Panel Mount Power Supply

PMR 1K0W series / PMR-□V1K0W1BT

Protections

Overvoltage	13.2 V - 16.8 V SELV Output, Auto-Recovery	28.0 V - 34.0 V SELV Output, Auto-Recovery	39.6 V - 48.6 V SELV Output, Auto-Recovery	55.0 V – 68.0 V SELV Output, Auto-Recovery
Overload / Overcurrent	<150% of rated load current, Auto-recovery Continuous current limit Mode*5 (Vo > 80%)			
Over Temperature	Auto-Recovery			
Short Circuit	Auto-Recovery, Non-Latching (Auto-Recovery when the fault is removed)			
Internal Fuse at L pin	T20 A / 420 V			
Protection Against Shock	Class I with PE*6 connection			

*5 Constant current limit protection for inductive and capacitive load applications

*6 PE: Protection Earth

Reliability Data

MTBF	> 700,000 hrs as per Telcordia SR-332 (I/P: 230 Vac, O/P: 100% Load, Ta: 25°C)
Expected Cap Life Time	10 years (230 Vac, 50% load @ 40°C)

Safety Standards / Directives

Safety Entry Low	SELV	
Electrical Safety	TUV Bauart UL/cUL CB scheme EAC BSMI CQC BIS	EN 62368-1, EN 60335-1 UL 62368-1, and CAN/CSA C22.2 No. 62368-1 IEC 62368-1, IEC 60335-1, IEC/EN 61558-1/-2-16 TP TC 004/2011 CNS 15598-1 GB4943.1-2022 IS 13252(Part 1)
CE	In conformance with EMC Directive 2014/30/EU and Low Voltage Directive 2014/35/EU	
UKCA	In conformance with Electromagnetic Compatibility Regulations 2016 and Electrical Equipment (Safety) Regulations 2016	
Galvanic Isolation	Input to Output	4.0 KVac
	Input to Ground	2.0 KVac
	Output to Ground	1.25 KVac

PMR Panel Mount Power Supply

PMR 1K0W series / PMR-□V1K0W1BT

EMC**7

Emissions (CE & RE)	CISPR 32, EN/BS EN 55032, KS C 9832, AS/NZS CISPR32 & Compliance to FCC Title 47, EN/BS EN 55014-1, EN/BS 61000-6-3, EN/BS EN 61000-6-4 : Class B		
Immunity	EN/BS EN 55035, KS C 9835, & Compliance to EN/ BS EN 55014-2 , EN/BS EN 61000-6-1, EN/BS EN 61000-6-2		
Electrostatic Discharge	IEC 61000-4-2	Level 4 Criteria A ¹⁾ Air Discharge: 15 kV Contact Discharge: 8 kV	
Radiated Field	IEC 61000-4-3	Level 3 Criteria A ¹⁾ 80 MHz – 1 GHz, 10 V/M, 80% Modulation (1 kHz) 1.4 GHz – 6 GHz, 3 V/M, 80% Modulation (1 kHz)	
Electrical Fast Transient / Burst	IEC 61000-4-4	Level 3 Criteria A ¹⁾ 2 kV	
Surge	IEC 61000-4-5	Level 4 Criteria A ¹⁾ Common Mode ⁴⁾ : 4 kV Differential Mode ⁵⁾ : 2 kV	
Conducted	IEC 61000-4-6	Level 3 Criteria A ¹⁾ 150 kHz-80 MHz, 10 Vrms	
Power Frequency Magnetic Fields	IEC 61000-4-8	Level 4 Criteria A ¹⁾ 30 A/Meter	
Voltage Dips and Interruptions	IEC 61000-4-11	0% residual; 1 cycle, Criteria B ²⁾ 40% residual; 10 cycle, Criteria C ³⁾ 70% residual; 25 cycle, Criteria C ³⁾	
Harmonic Current Emission	IEC/EN/BS EN 61000-3-2, Class A		
Voltage Fluctuation and Flicker	IEC/EN/BS EN 61000-3-3		
Voltage Sag Immunity SEMI F47 – 0706	80% of 200 Vac 70% of 200 Vac 50% of 200 Vac	160 Vac, 1000 ms 140 Vac, 500 ms 100 Vac, 200 ms	Criteria A ¹⁾ Criteria A ¹⁾ Criteria A ¹⁾

1) Criteria A: Normal performance within the specification limits

2) Criteria B: Output out of regulation, or shuts down during test. Automatically restored to normal operation after test.

3) Criteria C: Output out of regulation, shuts down during test (Need to recycle AC power cord to normal operation after test)

4) Asymmetrical: Common mode (Line to earth)

5) Symmetrical: Differential mode (Line to line)

6) Power supply is considered a component in the end-user's system. Please contact our local sales to get more information about the power supply EMC test setup.

PMR Panel Mount Power Supply

PMR 1K0W series / PMR-□V1K0W1BT

Block Diagram

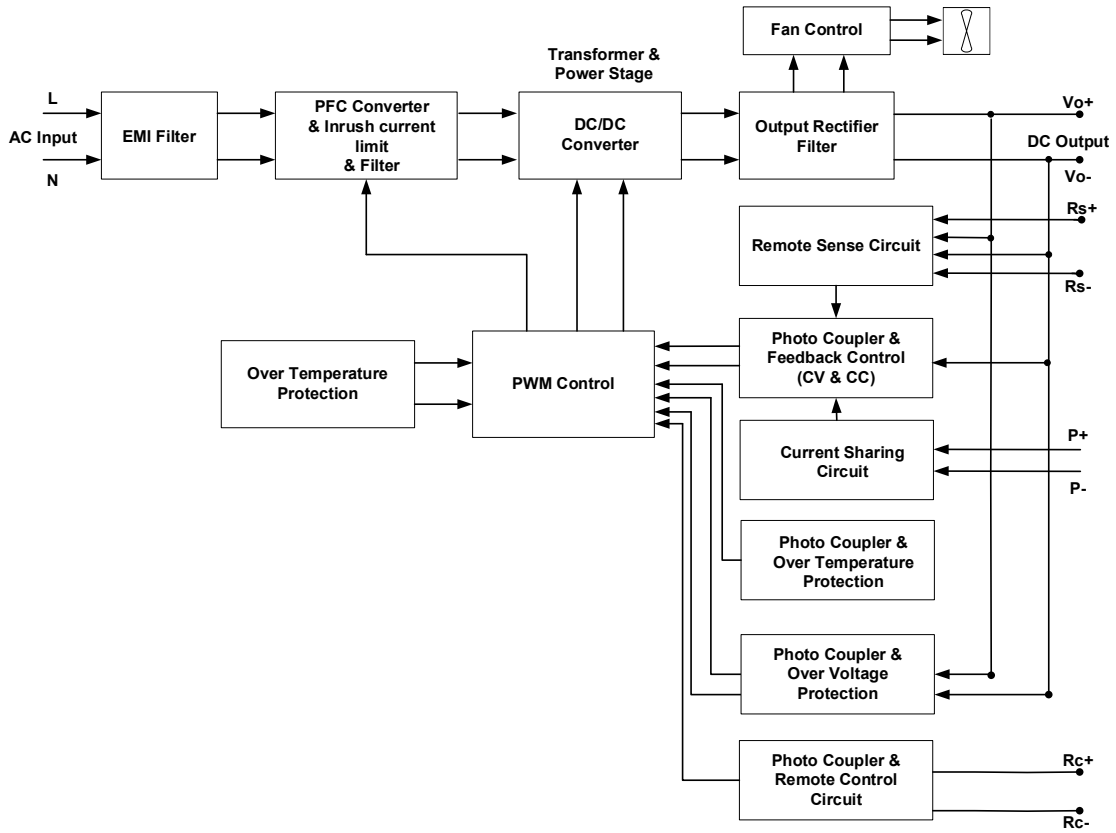

Device Descriptions

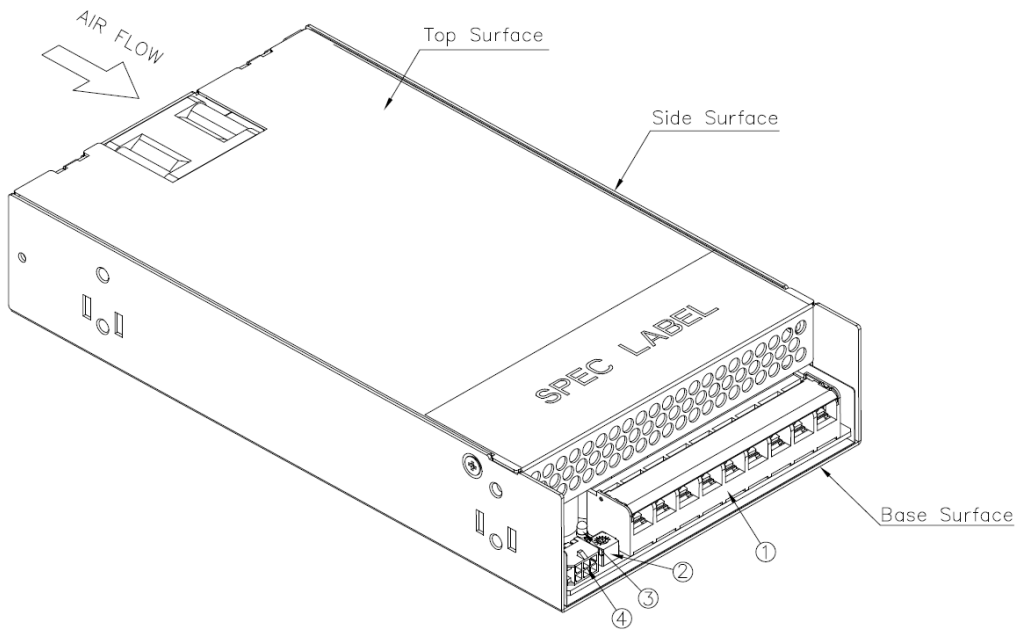

- 1) Input & Output terminal block connector
- 2) DC voltage adjustment potentiometer
- 3) DC OK control LED (Green)
- 4) Remote ON/OFF and Remote Sense connector

PMR Panel Mount Power Supply

PMR 1K0W series / PMR-□V1K0W1BT

Dimensions

L x W x H: 225 x 124 x 41 mm (8.86 x 4.88 x 1.61 inch)

Mechanical drawing

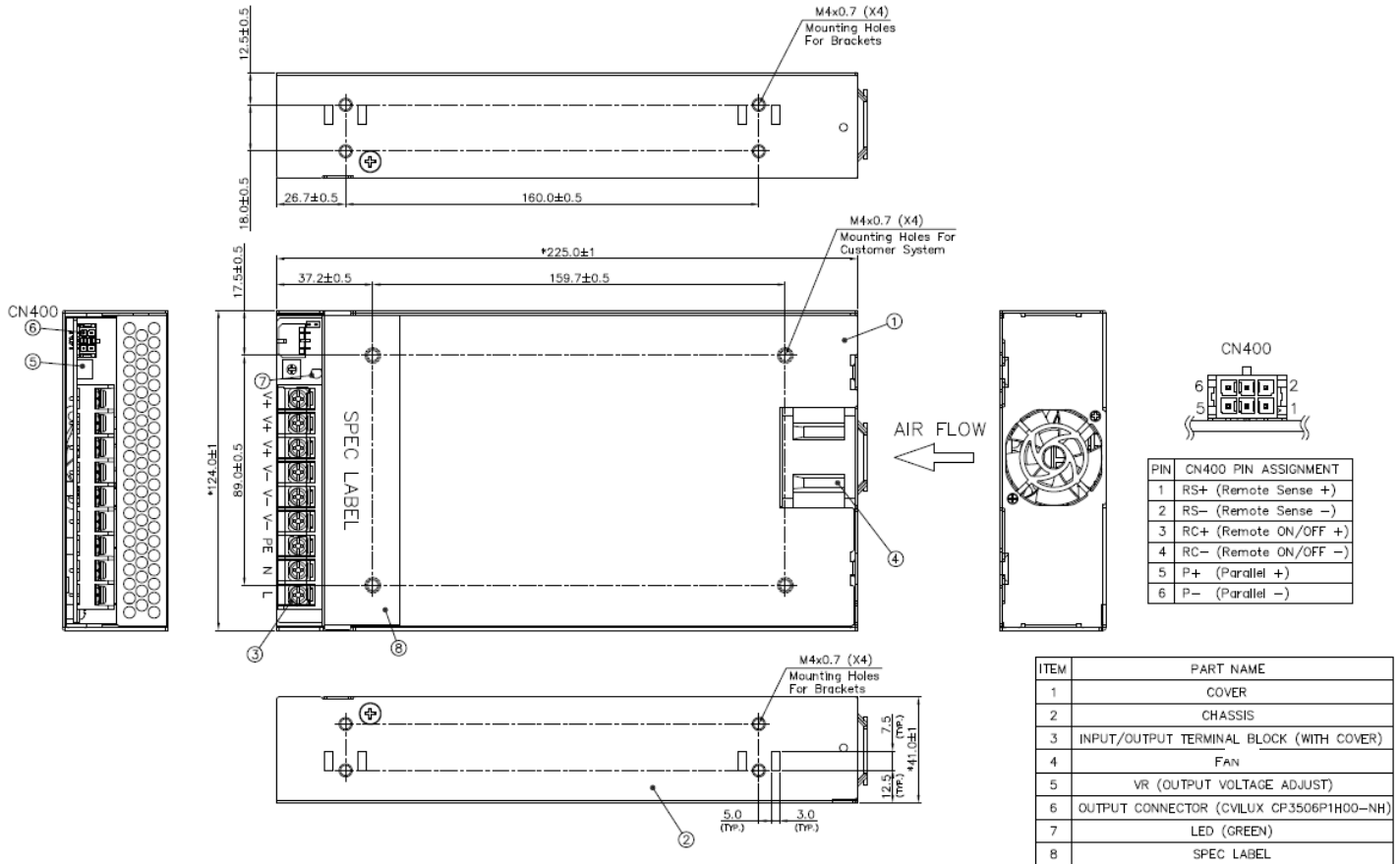

Note : Built-in cooling fan. Must prevent dust suction into power supply, or use natural convection power supply if any concerns.

Wire AWG Table

Current rating for PVC Wire AWG			
6 AWG	52.5A	20 AWG	6.5A
8 AWG	37.5A	22 AWG	5.0A
10 AWG	29.0A	24 AWG	3.5A
12 AWG	22.5A	26 AWG	2.5A
14 AWG	16.5A	28 AWG	2.0A
16 AWG	12.0A	30 AWG	1.5A
18 AWG	9.0A		

PMR Panel Mount Power Supply

PMR 1K0W series / PMR-□V1K0W1BT

Engineering Data

Output Load De-rating VS Surrounding Air Temperature

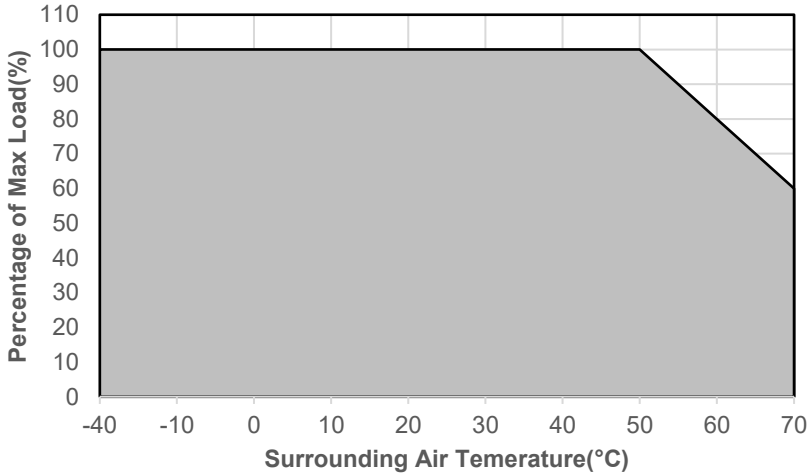
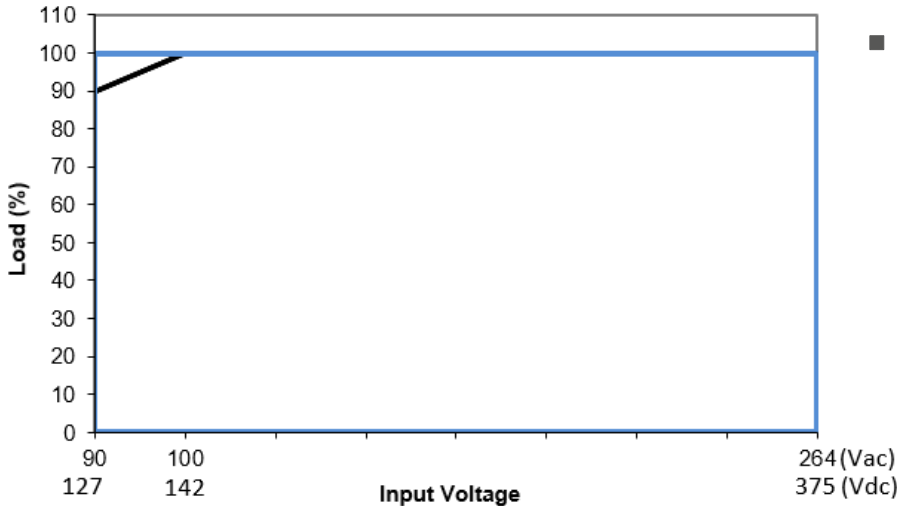

Fig. 1 De-rating for Horizontal Mounting Orientation
 > 50°C de-rate power by 2.0% / °C

Note

1. Power supply components may degrade, or be damaged, when the power supply is continuously used outside the shaded region, refer to the graph shown in Fig. 1 & Fig. 2.
2. The power supply will have long rise time when the ambient temperature range is -30°C to -40°C.
3. If the output capacity is not reduced when the surrounding air temperature >50°C, the device will run into Over Temperature Protection. When activated, power supply will latch off, until the surrounding air temperature is lowered or the load is reduced as far as necessary to keep the device in working condition, and require removal/re-application of input AC voltage in order to restart.
4. In order for the device to function in the manner intended, it is also necessary to keep a safety distance as recommended in the safety instructions while the device is in operation.
5. Depending on the surrounding air temperature and output load delivered by the power supply, the device can be very hot!

Output Load De-rating VS Input Voltage



■ No output power de-rating for the input voltage from 100 Vac to 264 Vac & 127 Vdc to 375 Vdc

Fig. 2 De-rating for AC Input Voltage
 < 100Vac de-rate power by 1% / V (90% load @ 90 Vac)
 No de-rate power for DC Input

PMR Panel Mount Power Supply

PMR 1K0W series / PMR-□V1K0W1BT

Assembly & Installation

- Ⓐ Mounting: Fig.3 shows the mounting hole locations for power supply assembly onto a metal mounting surface.
- Ⓑ This surface belongs to customer's end system or panel where the power supply is mounted.
- Ⓒ Connector

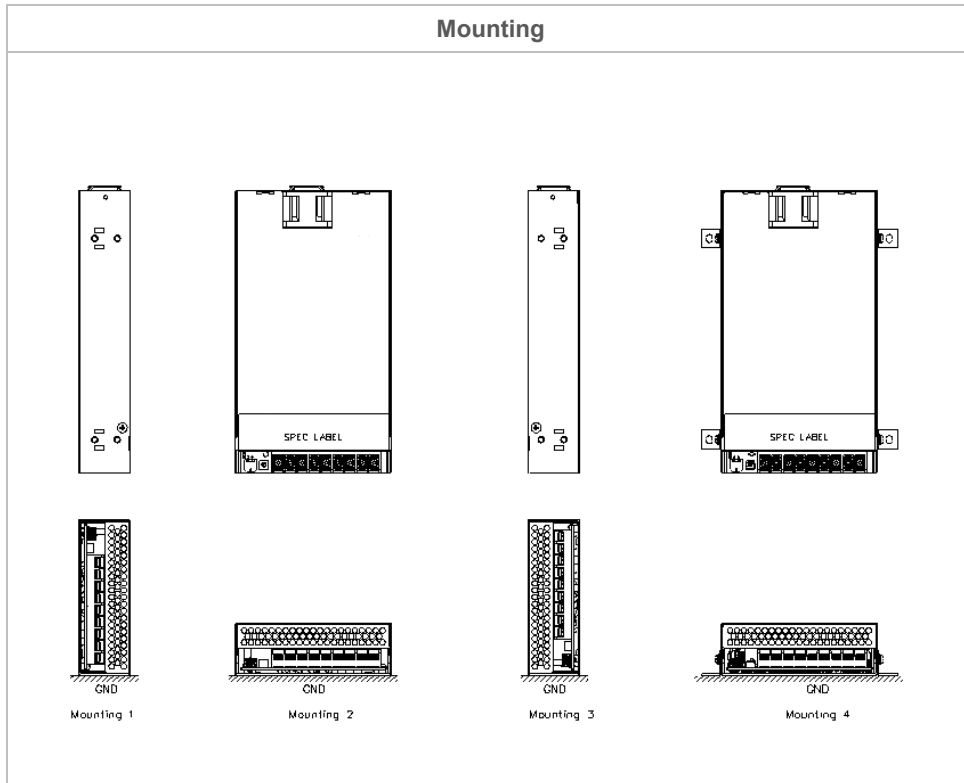

* If the device has to be mounted in any other orientation, please leave a message via the [Contact Us](#) form.

- Use flexible cable (stranded or solid) of AWG No.14-10. User should calculate and select the suitable wire specification (type/quantity/diameter) according to actual output current. The torque at the Connector shall not exceed 10.2 Kgf.cm. (8.85 lbf.in). The insulation stripping length should not exceed 0.275" or 7 mm. (Refer to Fig. 3).

Installation of Mounting Accessories

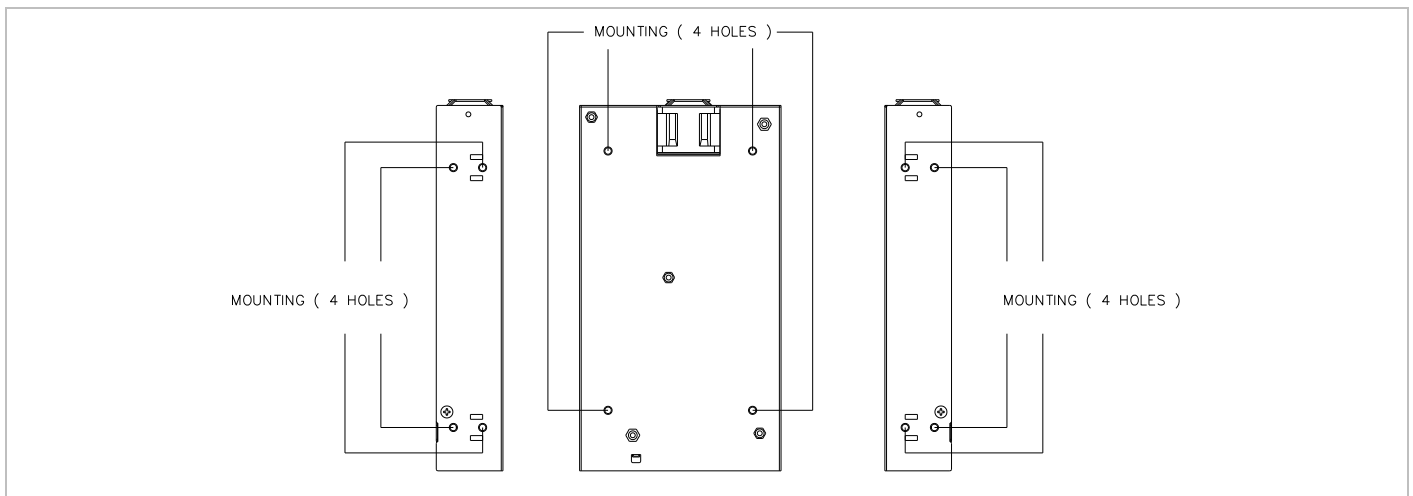
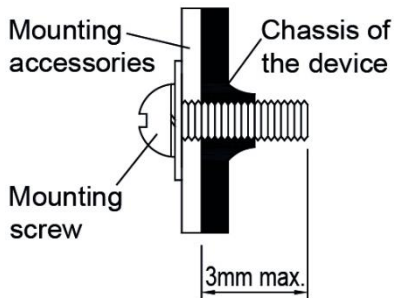

Fig. 3 Assembly Reference

PMR Panel Mount Power Supply

PMR 1K0W series / PMR-□V1K0W1BT



- Only use M4 screw ≤ 3 mm (0.20 inch) through the base mounting holes. This is to keep a safe distance between the screw and internal components.
- Recommended mounting tightening torque: 4~7 Kgf.cm (3.47~6.08 lbf.in).

Fig. 4 Mounting Screw

Safety Instructions

- If user's mounting orientation is not according to the recommended mounting orientations, please consult Delta for further information.
- To ensure sufficient convection cooling, always maintain a safety distance of ≥ 50 mm (1.97 inch) from all ventilated surfaces while the device is in operation.
- The device is not recommended to be placed on low thermal conductive surface. For example, plastics.
- The enclosure of the device can become very hot depending on the ambient temperature and load of the power supply. Do not touch the device while it is in operation or immediately after power is turned OFF. Risk of burning!
- Do not touch the terminals while power is being supplied. Risk of electric shock.
- Prevent any foreign metal, particles or conductors from entering the device through the openings during installation. It may cause: Electric shock; Safety Hazard; Fire; Product failure
- The power supply must be mounted by metal screws onto a grounded metal surface. It is highly recommended that the Earth terminal on the connector be connected to the grounded surface.

PMR Panel Mount Power Supply

PMR 1K0W series / PMR-□V1K0W1BT

Functional Manual

Remote ON/OFF Function

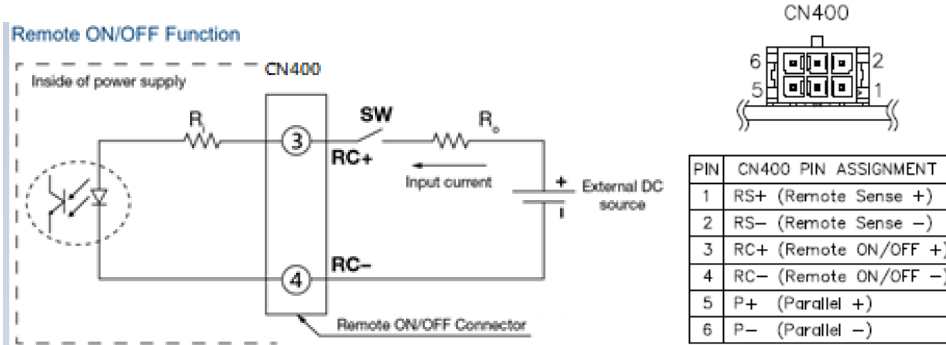

You can remotely control the power supply unit to turn ON/OFF by using an external DC source. Follow the DC power source voltage and current limiting defined in the table below.

Built-in Resistor R_i (ohm)	Voltage Between RC+ and RC- (V)		Input Current (mA)
	Output ON	Output OFF	
1500	0-0.5	5-12.5	20 Max

Notes

- Remote ON/OFF circuits are isolated from input, output and PE.
- Please check if the polarity of the wire connector is the same as the external DC source. If not, the power would not turn on and the internal components may be damaged.
- You do not need an external resistance R_0 for current limit while the output voltage of external DC source is within the range of 5-12.5 V. If the output voltage exceeds 12.5 V, please use the following equation for the value of current limit resistance R_0 .

$$R_0 = \frac{V_{cc} - (3.5 + 0.006R_i)}{0.006}$$

Remote Sensing Function

This function compensates voltage drop of wiring from output terminals to load terminals. Connect "RS+" of CN400 terminal to "V+" terminal of load and "RS-" of CN400 terminal to "V-" terminal of load with sensing wires. The total compensates voltage drop up to 0.5V.

* In case that output wiring is too long and wire AWG is too small, OVP may be triggered, please [Contact Us](#) for more details.

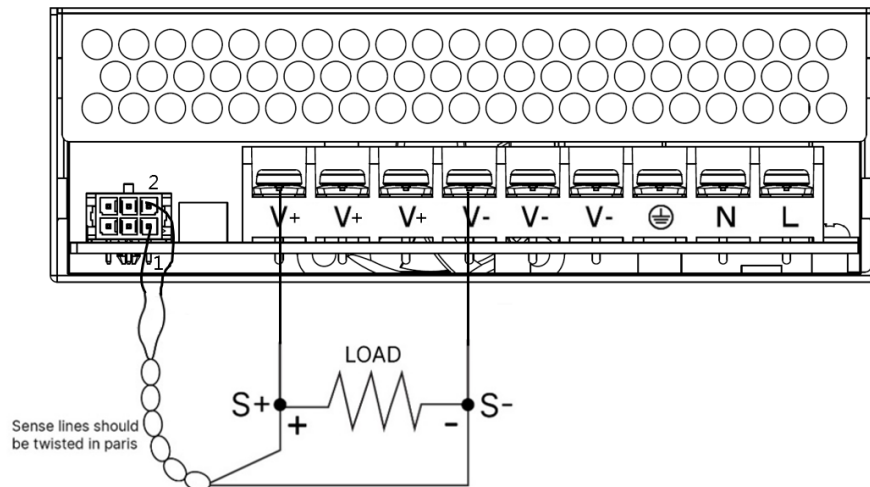

PMR Panel Mount Power Supply

PMR 1K0W series / PMR-□V1K0W1BT

Functions

Start-up Time

The time required for the output voltage to reach 90% of its final steady state set value, after the input voltage is applied.

Rise Time

The time required for the output voltage to change from 10% to 90% of its final steady state set value.

Hold-up Time

Time between the collapse of the AC input voltage, and the output falling to 95% of its steady state set value.

■ Graph illustrating the Start-up Time, Rise Time, and Hold-up Time

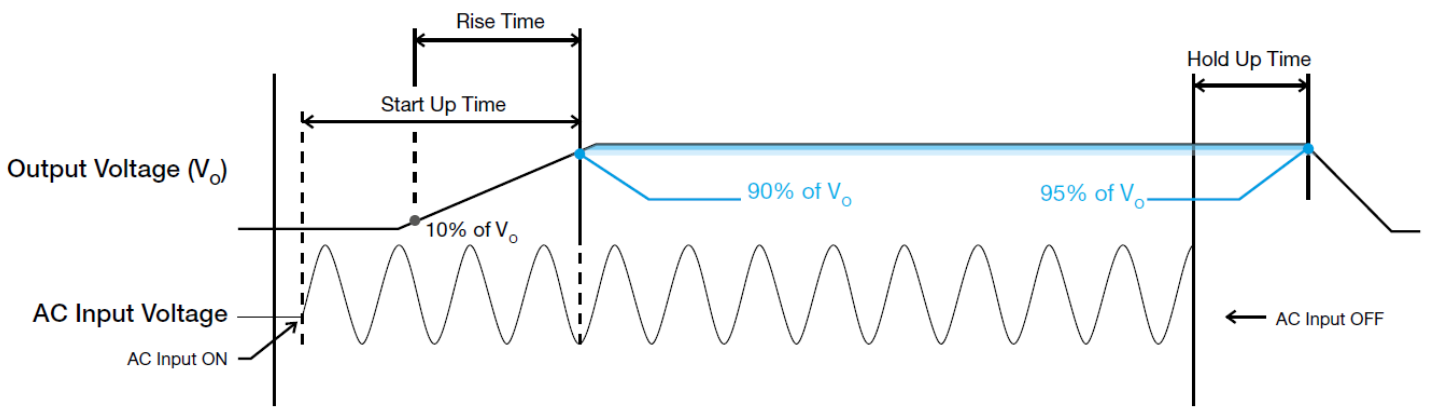

Inrush Current

Inrush current is the peak, instantaneous, input current measured and, occurs when the input voltage is first applied. For AC input voltages, the maximum peak value of inrush current will occur during the first half cycle of the applied AC voltage. This peak value decreases exponentially during subsequent cycles of AC voltage.

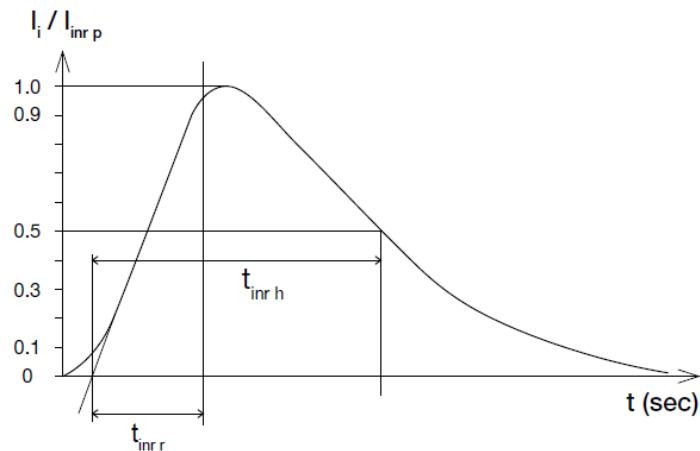

Dynamic Response

The power supply output voltage will remain within $\pm 10\%$ of its steady state value, when subjected to a dynamic load from 10% to 100%.

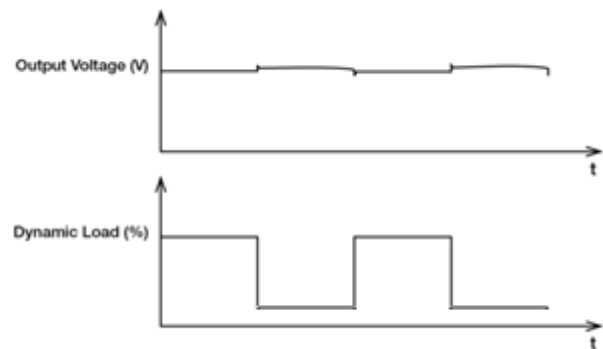

PMR Panel Mount Power Supply

PMR 1K0W series / PMR-□V1K0W1BT

Overload & Overcurrent Protections (Continuous Current)

The power supply offers constant current limit protection for inductive and capacitive load applications when output current range is <math><150\%</math> of I_o (Max load) and output voltage large than 80%. Upon such an occurrence, the V_o (output voltage) will start to droop. Once the power supply has reached its maximum power limit, the protection will be activated; and, the power supply will operate in continuous current. The power supply will recover once the cause of OLP or OCP is removed, and I_o (output current) is back within the specified range.

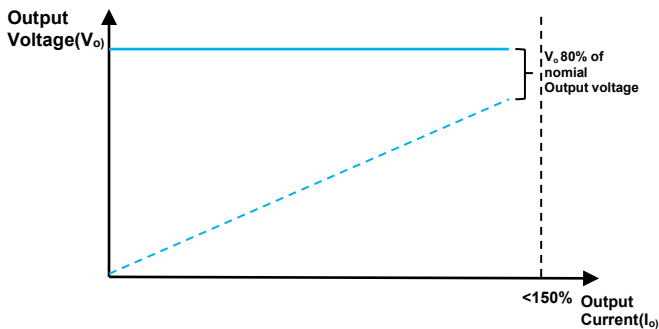

It is not recommended to prolong the duration of I_o when it is <math><110\%</math> but >math>100\%</math>, since it may cause damage to the PSU.

Short Circuit Protection (Auto-Recovery)

The power supply's output OLP/OCP function also provides protection against short circuits. When a short circuit is applied, the output current will operate in "Hiccup mode", as shown in the illustration in the OLP/OCP section on this page. The power supply will return to normal operation after the short circuit is removed.

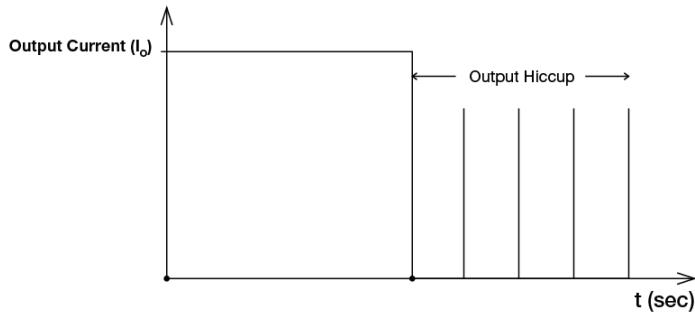

Overvoltage Protection (Auto-Recovery)

The power supply's overvoltage circuit will be activated when its internal feedback circuit fails. The output voltage shall not exceed its specifications defined on Page 4 under "Protections".

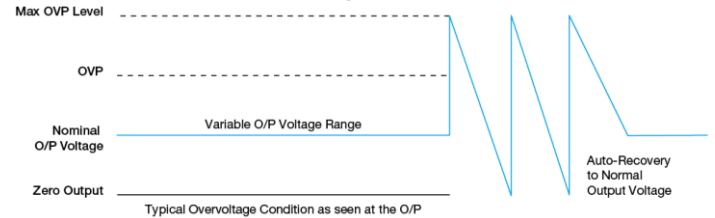

Over Temperature Protection (Auto-Recovery)

As described in load de-rating section, the power supply also has Over Temperature Protection (OTP). In the event of a higher operating temperature at 100% load, the power supply will run into OTP when the operating temperature is beyond what is recommended in the de-rating graph. When activated, the output voltage will go into bouncing mode until the temperature drops to its normal operating temperature as recommended in the de-rating graph.

Current Sharing

The power supply supports parallel current sharing function. Two power supply main outputs are connected in parallel and connected. The Current Share port can enable this function Pin5 of CN400, refer to the power structure diagram and lead Foot definition), up to four power supplies can be connected in parallel. The difference in power output voltage will affect when the power supply is connected in parallel, adjust the voltage difference between different power supplies to within ± 200 mV, and ensure that the maximum output current does not exceed 90% of the rated current.

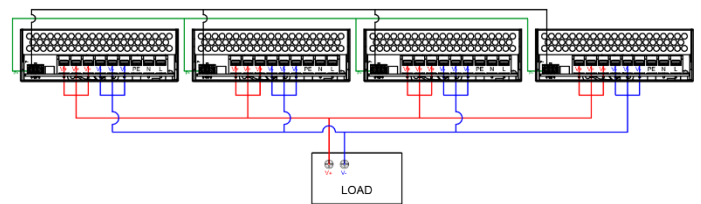

PMR Panel Mount Power Supply

PMR 1K0W series / PMR-□V1K0W1BT

Others

Attention

Delta provides all information in the datasheets on an "AS IS" basis and does not offer any kind of warranty through the information for using the product. In the event of any discrepancy between the information in the catalog and datasheets, the datasheets shall prevail (please refer to PSU.deltaww.com for the latest datasheets information). Delta shall have no liability of indemnification for any claim or action arising from any error for the provided information in the datasheets. Customer shall take its responsibility for evaluation of using the product before placing an order with Delta.

Delta reserves the right to make changes to the information described in the datasheets without notice.

Manufacturer and Authorized Representatives Information

Manufacturer

Thailand

Delta Electronics (Thailand) PCL.
909 Pattana 1 Rd., Muang, Samutprakarn, 10280 Thailand

Taiwan

Delta Electronics, Inc.
3 Tungyuan Road, Chungli Industrial Zone, Taoyuan County
32063, Taiwan

Authorized Representatives

The Netherlands

Delta Greentech (Netherlands) B.V.
Zandsteen 15, 2132 MZ Hoofddorp, The Netherlands

United Kingdom

Delta Electronics Europe Limited
1 Redwood Court, Peel Park Campus,
East Kilbride, Glasgow, G74 5PF, United Kingdom