

# LYTE II Series DIN Rail Power Supply

## DRL-960W Series / DRL-□V960W1EN□

# LYTE II



### Highlights & Features

- Wide AC input voltage range 85-277 Vac
- Power Boost up to 150% for 5 seconds
- Slim and compact size design
- Wide operating temperature range from -40°C to +70°C
- Power good LED indicator
- Surge protection capacity 4 kV / 2 kV
- IEC/EN/UL 62368, IEC/UL 61010, and IEC 61558 certified
- Compliant with SEMI F47 standard

### Safety Standards



CB Certified for worldwide use

<b>Model Number:</b>	DRL-□V960W1EN□
<b>Unit Weight:</b>	2.05 kg (4.52 lb)
<b>Dimensions (H x W x D):</b>	123.6 x 103.8 x 137 mm (4.87 x 4.09 x 5.39 inch)

### General Description

Delta's LYTE II DIN rail power supply Series is designed for cost-sensitive users who need to fulfill essential features needed for many general industrial applications, without compromising on quality and reliability. The convection-cooled LYTE II Series will operate full power from -40°C to +50°C, then derating up to +70°C at 230 Vac. It also supports a 150% Power Boost function, making it suitable for both inductive and capacitive loads. The Series is certified according to safety standards IEC/EN/UL 62368, IEC/UL 61010, and IEC 61558. In addition, radiated and conducted electromagnetic emissions comply with Class B limits. The products also meet environmental protection requirements in accordance with the RoHS and REACH directives.

### Model Information

LYTE II DIN Rail Power Supply

Model Number	Input Voltage Range	Rated Output Voltage	Rated Output Current
DRL-24V960W1EN□	85-277 Vac	24 Vdc	40 A
DRL-48V960W1EN□	(100-400 Vdc)	48 Vdc	20 A

### Model Numbering

DR	L -	□V	960W	1	E	N	□
DIN Rail	Product Series L - LYTE Family	Output Voltage 24 - 24 V 48 - 48 V	Output Power	Single Phase	E: Slim Design	N: No DC OK relay contact	A: Option Type for Conformal Coating

# LYTE II Series DIN Rail Power Supply

## DRL-960W Series / DRL-□V960W1EN□

### Specifications

Model Number	DRL-24V960W1EN□	DRL-48V960W1EN□
--------------	-----------------	-----------------

#### Input Ratings / Characteristics\*1

Nominal Input Voltage	100-240 Vac	
Input Voltage Range	85-277 Vac	
Nominal Input Frequency	50-60 Hz	
Input Frequency Range	47-63 Hz	
DC Input Voltage Range*2	100-400 Vdc (Please refer to page 8 derating curve)	
Input Current	9.3 A typ. @ 115 Vac, 4.6 A typ. @ 230 Vac	
Efficiency at 100% Load	95% typ. @ 230 Vac	95.5% typ. @ 230 Vac
No Load Power Consumption	4 W typ. @ 230 Vac	4.5 W typ. @ 230 Vac
Max Inrush Current (Cold Start)	30 A typ. @ 230 Vac	
Power Factor at 100% Load	> 0.98 @ 115 Vac, > 0.96 @ 230 Vac	
Leakage Current	1.5 mA typ. @ 230 Vac	

\*1 All parameters not specially mentioned are measured at 230 Vac input and 25°C ambient temperature.

\*2 Power Supply can operate at DC Input voltage, please connect +pole to L, -pole to N and PE terminal to an earth wire or to the machine ground.

#### Output Ratings / Characteristics

Nominal Output Voltage	24 Vdc	48 Vdc
Factory Set Point Tolerance	24 Vdc ± 1%	48 Vdc ± 1%
Output Voltage Adjustment Range	24-28 Vdc	48-55 Vdc
Output Current	0-40.0 A	0-20.0 A
Output Power	960 W max	
Line Regulation	± 0.5% @ 115 Vac & 230 Vac	
Load Regulation	± 0.5%	
PARD*3 (20 MHz)	< 150 mVpp @ 0°C to +70°C < 450 mVpp @ -30°C to 0°C	< 200 mVpp @ 0°C to +70°C < 600 mVpp @ -30°C to 0°C
Rise Time	30 ms typ. @ 230 Vac	
Start-up Time	300 ms typ. @ 230 Vac	
Hold-up Time	22 ms typ. @ 230 Vac	
Dynamic Response (Overshoot & Undershoot O/P Voltage)	± 10% @ 115 Vac & 230 Vac input, 10-100% load (Slew Rate: 2.5 A/μS, 50% duty cycle @ 5 Hz & 10 kHz)	
Start-up with Capacitive Loads	10,000 μF Max	5,000 μF Max

\*3 PARD is measured with an AC coupling mode, 5cm wires, and in parallel to end terminal with 0.1 μF ceramic capacitor & 47 μF electrolytic capacitor. PSU need to burn in around 5 minutes when ambient temperature ≤ 0°C.

# LYTE II Series DIN Rail Power Supply

## DRL-960W Series / DRL-□V960W1EN□

<b>Model Number</b>	DRL-24V960W1EN□	DRL-48V960W1EN□
---------------------	-----------------	-----------------

### Mechanical

Case Cover	Aluminum alloy		
Chassis	Anodized aluminum		
Front Cover	Galvanized steel		
Dimensions (H x W x D)	123.6 x 103.8 x 137 mm (4.87 x 4.09 x 5.39 inch)		
Unit Weight	2.05 kg (4.52 lb)		
Indicator	Green LED	DC OK	
Cooling System	Convection		
Terminal*4	Input	3 Pins (Rated 600 V / 30 A)	
	Output	4 Pins (Rated 600 V / 30 A)	
Wire	Input	AWG 14-12	AWG 14-12
	Output	AWG 12-10	AWG 16-14
Mounting Rail	Standard TS35 DIN Rail in accordance with EN 60715		
Noise (1 Meter from power supply)	Sound Pressure Level (SPL) < 25 dBA		

\*4 The torque at the screw terminal connector shall not exceed 5.2 Kgf.cm. (4.5 lbf.in).

### Environment

Surrounding Air Temperature*5/6	Operating	-40°C to +70°C (Please refer to page 8 derating curve)	
	Storage	-40°C to +85°C	
Power De-rating	Temperature	> 50°C de-rate power by 2.5 % / °C @ 230 Vac > 40°C de-rate power by 1.66 % / °C @ 115 Vac	
	Input Voltage	< 100Vac de-rate power by 1% / Vac	
Operating Humidity	5 to 90% RH (Non-Condensing)		
Operating Altitude	0 to 5,000 Meters (16,400 ft.)		
Shock Test	Non-Operating	IEC 60068-2-27, Half Sine Wave: 50 G for duration of 11 ms; 3 times per direction, 9 times in total	
Vibration	Non-Operating	IEC 60068-2-64, Random: 5 Hz to 500 Hz (2.09 G); 20 min per axis for all X, Y, Z direction	
	Operating	IEC 60068-2-6, Sine Wave: 10 Hz to 500 Hz (2G peak); 10 min per cycle, 60 min for X, Y, Z direction	
Over Voltage Category	II (Compliance to EN 61558-1 OVC III with 2000 meters altitude)		
Pollution Degree	2		

\*5 When operating at temperatures below -30°C, the PSU may require a few seconds to "bounce" before completing a cold-start power-up.

\*6 For power de-rating from 50°C to 70°C, see power de-rating on page 8.

# LYTE II Series DIN Rail Power Supply

## DRL-960W Series / DRL-□V960W1EN□

Model Number	DRL-24V960W1EN□	DRL-48V960W1EN□
--------------	-----------------	-----------------

### Protections

Overvoltage	<37 V, SELV Output, Hiccup Mode, Auto-recovery	<69 V, SELV Output, Hiccup Mode, Auto-recovery
Overload / Overcurrent	125 - 205% of rated load current, Hiccup Mode, Auto-recovery (150% Power Boost for 5 seconds / 200% for 50 ms / 500% for 5 ms)	
Over Temperature	Shut down, Auto-recovery	
Short Circuit	Hiccup Mode, Non-Latching (Auto-Recovery when the fault is removed)	
Protection Against Shock	Class I with PE*7 connection	

\*7 PE: Primary Earth

### Reliability Data

MTBF	Telcordia SR-332	> 700,000 hrs I/P: 115 Vac & 230 Vac, O/P: 100% load, Ta: 25°C
Expected Cap Life Time	10 Years (115 Vac & 230 Vac, 50% load @ 45°C)	
Warranty	3 Years (230 Vac, 80% load @ 50°C)	

### Safety Standards / Directives

Electrical Safety	CB scheme	IEC/EN/BS EN 62368-1, AS/NZS 62368-1 RCM, IEC/EN 61010-1/2-201, IEC 61558-1/2-16, AS/NZS 61558-1/2-16 RCM
	TUV Bauart	EN 62368-1
	UL/cUL	UL 62368-1, CSA C22.2; UL 61010-1/2-201, CAN/CSA-C22.2 No. 61010-1-12
	BIS	IS 13252-1 (Part 1)
	BSMI	CNS 15598-1
	CCC	GB4943.1
	EAC	TP TC 004/2011
	KC	KC 62368-1 (upon request)
CE	In conformance with EMC Directive 2014/30/EU and Low Voltage Directive 2014/35/EU	
UKCA	In conformance with Electrical Equipment (Safety) Regulations 2016 No. 1011 and The Electromagnetic Compatibility Regulations 2016 No. 1091	
SELV	IEC/EN 62368-1 /61010-1/2-201 /61558-1/2-16	
Galvanic Isolation*8	Input to Output	4.0 kVac
	Input to Ground	2.5 kVac
	Output to Ground	1.5 kVac

\*8 The Gas tube screw (L10) must be removed for Hi-Pot testing.

# LYTE II Series DIN Rail Power Supply

## DRL-960W Series / DRL-□V960W1EN□

Model Number	DRL-24V960W1EN□	DRL-48V960W1EN□
--------------	-----------------	-----------------

EMC\*9

Emissions (CE & RE)	CISPR 32, EN/BS EN 55032, AS/NZS CISPR 32, Class B; KS C 9832; CNS15936; EN/BS EN 61204-3; Compliance to FCC Title 47		
Immunity	EN/BS EN 55035; KS C 9835; EN/BS EN 61204-3		
Electrostatic Discharge	IEC 61000-4-2	Level 4 Criteria A <sup>1)</sup> Air Discharge: 15 kV Contact Discharge: 8 kV	
Radiated Field	IEC 61000-4-3	Criteria A <sup>1)</sup> 80 MHz – 1 GHz, 10 V/M, 80% Modulation (1 kHz) 1.4 GHz – 6 GHz, 3 V/M, 80% Modulation (1 kHz) 2 GHz – 2.7 GHz, 1 V/M, 80% Modulation (1 kHz)	
Electrical Fast Transient / Burst	IEC 61000-4-4	Level 4 Criteria A <sup>1)</sup> 4 kV	
Surge	IEC 61000-4-5	Level 4 Criteria A <sup>1)</sup>	
		Condition	W/O SPD
		Common Mode <sup>4)</sup>	4 kV
		Differential Mode <sup>5)</sup>	2 kV
Conducted Susceptibility	IEC 61000-4-6	Level 3 Criteria A <sup>1)</sup> 150 kHz – 80 MHz, 10 V rms	
Power Frequency Magnetic Fields	IEC 61000-4-8	Level 4 Criteria A <sup>1)</sup> 30 A/m	
Voltage Dips and Interruptions	IEC 61000-4-11	0% residual; 1 cycle, Criteria B <sup>2)</sup> 40% residual; 10 cycle, Criteria B <sup>3)</sup> 70% residual; 25 cycle, Criteria B <sup>3)</sup>	
Harmonic Current Emission	IEC/EN/BS EN 61000-3-2, Class A		
Voltage Fluctuation and Flicker	IEC/EN/BS EN 61000-3-3, dmax ≤ 4%		
Voltage Sag Immunity SEMI F47 – 0706	80% of 200 Vac 70% of 200 Vac 50% of 200 Vac	160 Vac, 1000 ms 140 Vac, 500 ms 100 Vac, 200 ms	Criteria A <sup>1)</sup> Criteria A <sup>1)</sup> Criteria A <sup>1)</sup>

1) Criteria A: Normal performance within the specification limits  
 2) Criteria B: Temporary degradation or loss of function which is self-recoverable  
 3) Criteria C: Output out of regulation, shuts down during test (Need to recycle AC power cord to normal operation after test)  
 4) Asymmetrical: Common mode (Line to earth)  
 5) Symmetrical: Differential mode (Line to line)

\*9 Power supply is considered a component in the end-user's system. Please contact our local sales to get more information about the power supply EMC test setup.



# LYTE II Series DIN Rail Power Supply

## DRL-960W Series / DRL-□V960W1EN□

### Block Diagram

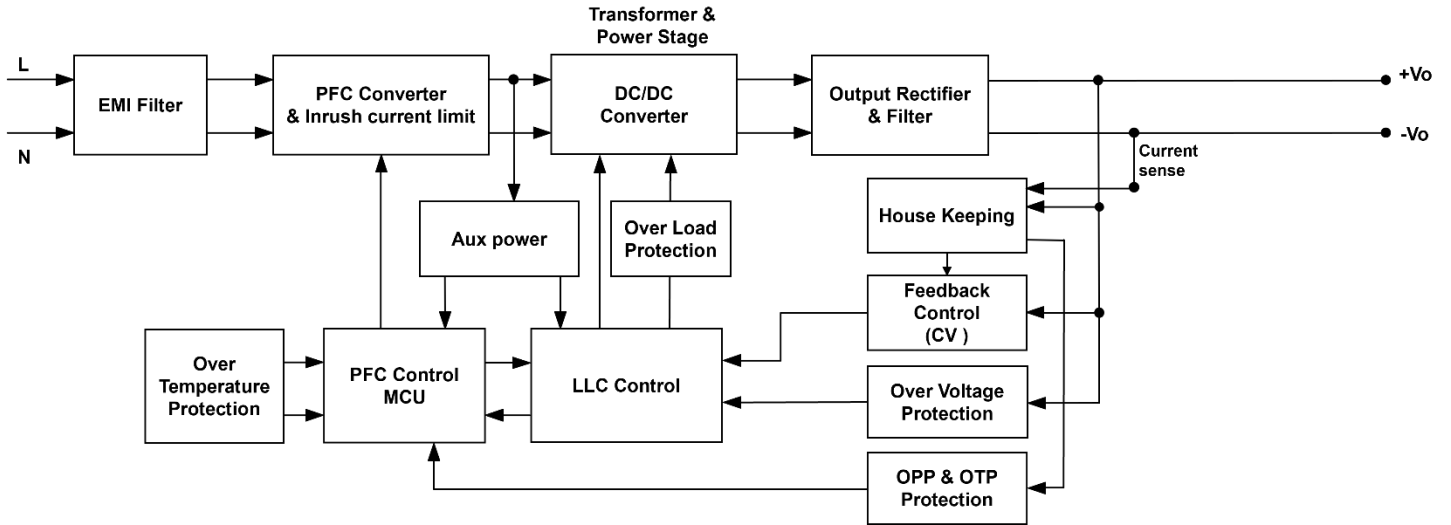

### Device Description

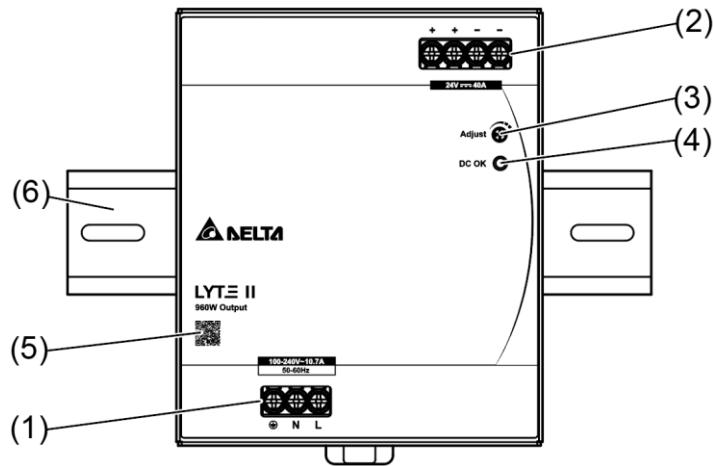

- 1) Input terminal block connector
- 2) Output terminal block connector
- 3) DC voltage adjustment potentiometer
- 4) DC OK LED (Green)
- 5) QR code for product datasheet link
- 6) Universal mounting rail system

# LYTE II Series DIN Rail Power Supply

## DRL-960W Series / DRL-□V960W1EN□

### Dimensions

H x W x D: 123.6 x 103.8 x 137 mm (4.87 x 4.09 x 5.39 inch)

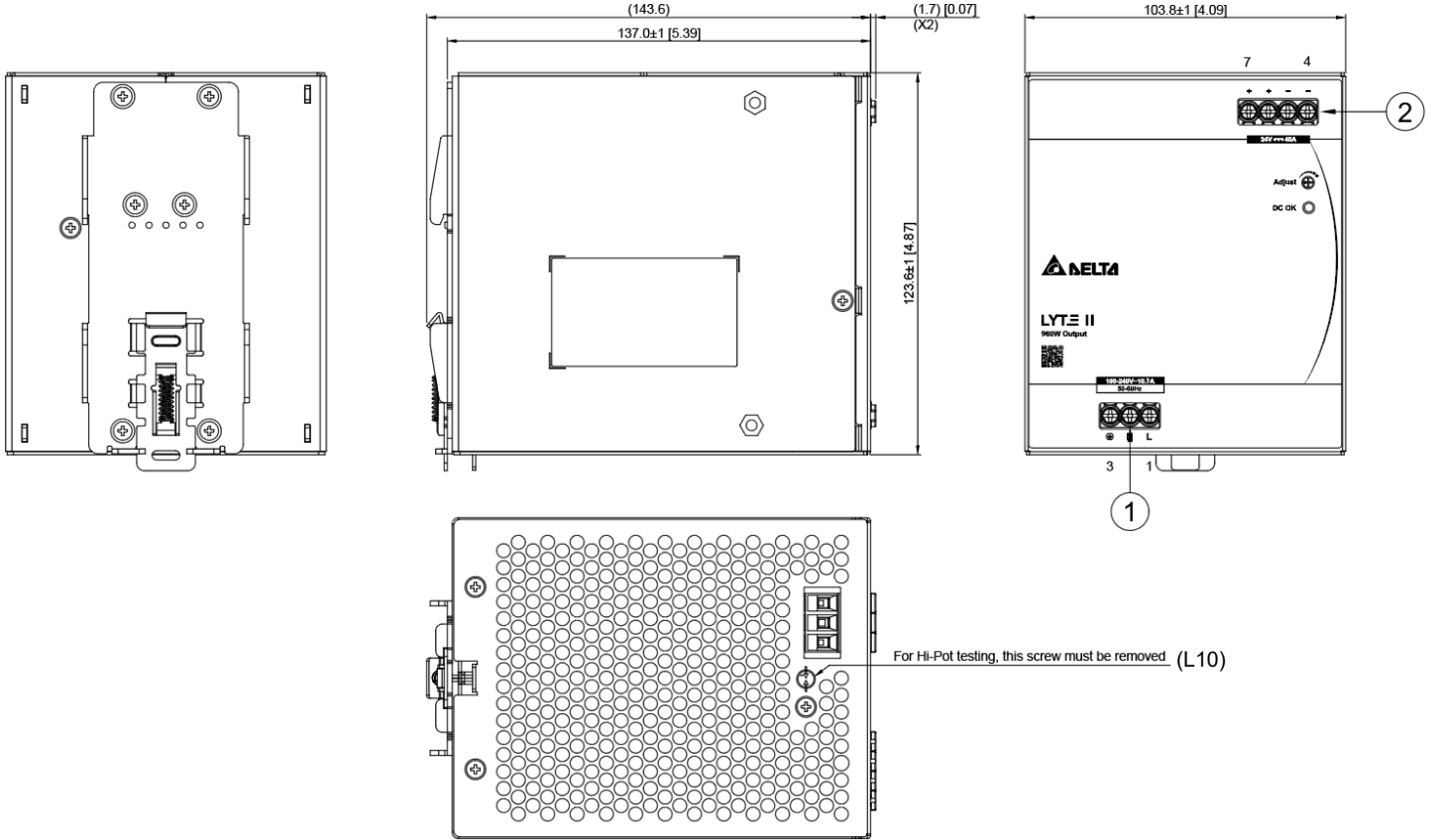

\*Unless otherwise specified tolerance of dimension are ± 0.5 mm

Item	Device Description
1	Input terminal block connector Pin 1: L Pin 2: N Pin 3: PE
2	Output terminal block connector Pin 4 to 5: V(-) Pin 6 to 7: V(+)

### Wiring Size:

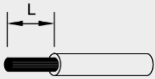
	Stranded / Solid		Torque		Stripping Length (mm) 
	(mm <sup>2</sup> )	(AWG)	(Kgf.cm)	(lbf.in)	
(1) Input	20.8-33.1	14-12	6.1	5.3	8
(2) Output	3.31-5.26 (24V) 1.31-2.08 (48V)	12-10 (24V) 16-14 (48V)	6.1	5.3	

# LYTE II Series DIN Rail Power Supply

## DRL-960W Series / DRL-□V960W1EN□

### Engineering Data

#### Output Load De-rating VS Surrounding Air Temperature

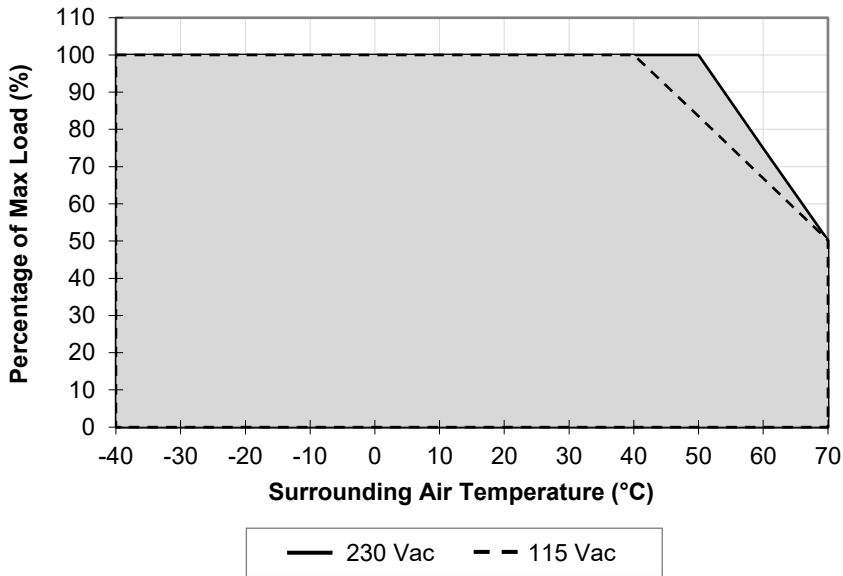

**Fig. 1 De-rating for Vertical Mounting Orientation**  
 > 50°C de-rate power by 2.5 % / °C @ 230 Vac  
 > 40°C de-rate power by 1.66 % / °C @ 115 Vac

Note: When operating at temperatures below -30°C, the PSU may require a few seconds to “bounce” before completing a cold-start power-up.

#### Note

1. Power supply components may degrade, or be damaged, when the power supply is continuously used outside the shaded region, refer to the graph shown in Fig. 1.
2. The power supply will have a longer rise time when the ambient temperature range is -30°C to -40°C.
3. If the output capacity is not reduced when the surrounding air temperature > 40°C (115 Vac) or > 50°C (230 Vac), the device will run into Over Temperature Protection. When activated, power supply will latch off, until the surrounding air temperature is lowered or the load is reduced as far as necessary to keep the device in working condition, and require removal/re-application of input AC voltage in order to restart.
4. In order for the device to function in the manner intended, it is also necessary to keep a safety distance as recommended in the safety instructions while the device is in operation.
5. Depending on the surrounding air temperature and output load delivered by the power supply, the device can be very hot!
6. Need to consider power de-rating if Surrounding Air Temperature is > 50°C.
7. If the device has to be mounted in any other orientation, please leave a message via the [Contact Us](#) form.

#### Output Load De-rating VS Input Voltage

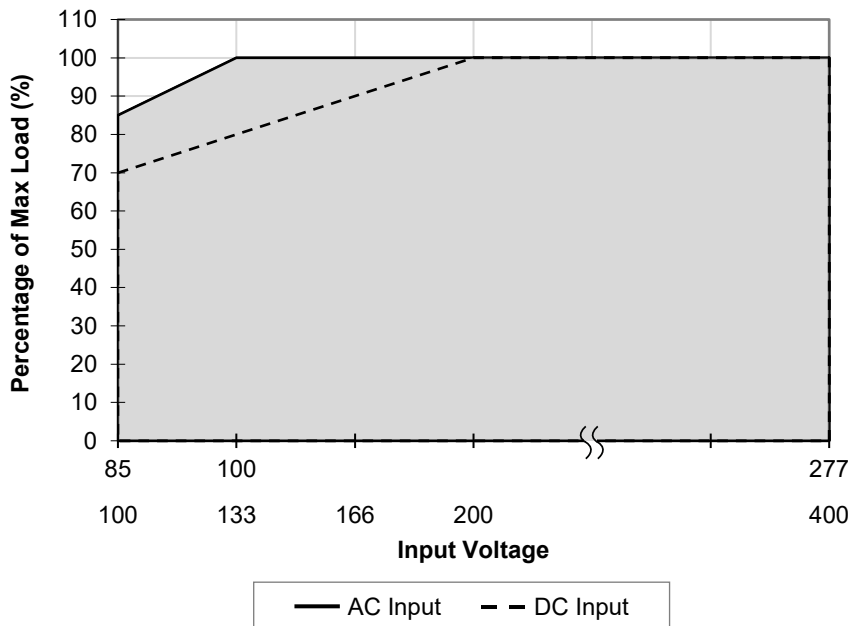

**Fig. 2 De-rating for AC & DC Input Voltage**  
 < 100 Vac de-rate power by 1% / Vac  
 < 200 Vdc de-rate power by 0.3% / Vdc

- No output power de-rating for the input voltage from 100 Vac to 277 Vac & 200 Vdc to 400 Vdc

# LYTE II Series DIN Rail Power Supply

## DRL-960W Series / DRL-□V960W1EN□

### Assembly & Installation

The power supply unit (PSU) can be mounted on 35 mm DIN rails in accordance with EN 60715. The device should be installed with input terminal block at the bottom.

Each device is delivered ready to install.

#### Mounting

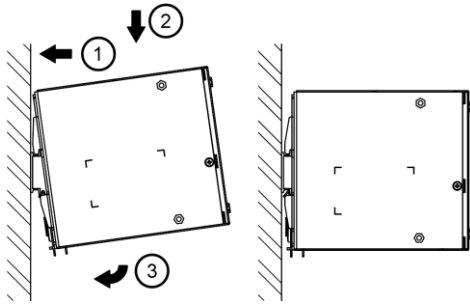

Fig. 3.1 Mounting

Snap on the DIN rail as shown in Fig. 3.1:

1. Tilt the unit upwards and insert it onto the DIN rail.
2. Push downwards until stopped.
3. Press against the bottom front side for locking.
4. Shake the unit slightly to ensure that it is secured.

#### Dismounting

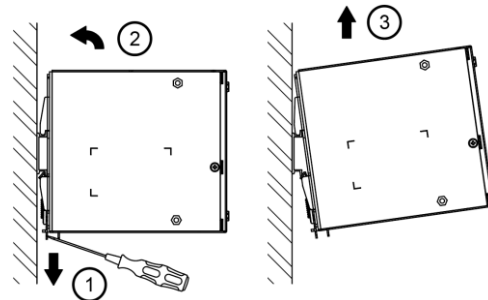
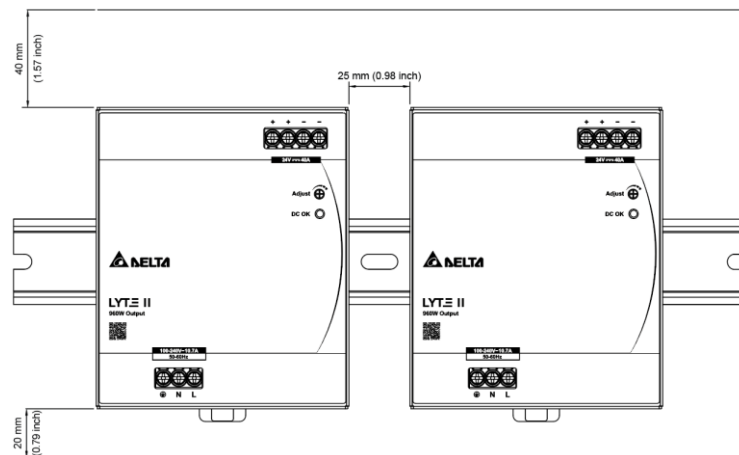

Fig. 3.2 Dismounting

To uninstall, Delta provides an easy way to pull or slide down the latch with screw driver as shown in Fig. 3.2. Then slide the power supply unit (PSU) in the opposite direction, release the latch and pull out the power supply unit (PSU) from the rail.

### Safety Instructions

#### Vertical Mounting



- ALWAYS switch mains of input power OFF before connecting and disconnecting the input voltage to the unit. If mains are not turned OFF, there is risk of explosion / severe damage.
- To guarantee sufficient convection cooling, keep a distance of 40 mm (1.57 inch) above and 20 mm (0.79 inch) below. If load is less than 50%, lateral distance can be 0 mm (0 inch). In case the adjacent device is a heat source, the lateral distance will be 15 mm (0.59 in) for 80% load or > 25 mm (0.98 inch) lateral distance condition for 100% load @ 50°C ambient temperature.
- Note that the enclosure of the device can become very hot depending on the surrounding air temperature and load of the power supply. Risk of burns!
- The main power must be turned off before connecting or disconnecting wires to the terminals.
- DO NOT insert any objects into the unit.
- Hazardous voltages may be present for up to 5 minutes after the input mains voltage is disconnected. Do not touch the unit during this time.
- The power supplies are built in units and must be installed in a cabinet or room (condensation free environment and indoor location) that is relatively free of conductive contaminants.
- For detailed product installation and notice, please refer the user manual.

# LYTE II Series DIN Rail Power Supply

## DRL-960W Series / DRL-□V960W1EN□

### Functions

#### LED Indicator Characteristics

Operating Status	DC OK (Green LED)
Normal Operation	ON
Overload (Hiccup Mode)	INTERMITTENT
Output Short Circuit	INTERMITTENT
Over Temperature	OFF
No Input Power	OFF
Over Voltage Warning (OVW)	Flash / 1 HZ
External Over Voltage Warning (EOVW) (Back EMF Situation)	Flash / 5 HZ

### Power Boost

Power Boost is the reserve power available constantly that allows reliable startup to support sudden and short spike of loads with high inrush current typically during turn on to remove the need of more expensive higher rated power supply unit. After the output has reached its steady state set value, the power supply can support surge loads with a higher short-term power demand up to 150% of maximum rated load ( $I_o$  Max), for a maximum duration of 5 seconds. The Power Boost function can also be applied on a repetitive basis, provided that the average (RMS) output power does not exceed the continuous operating rating. Please refer to the duty cycle calculation below.

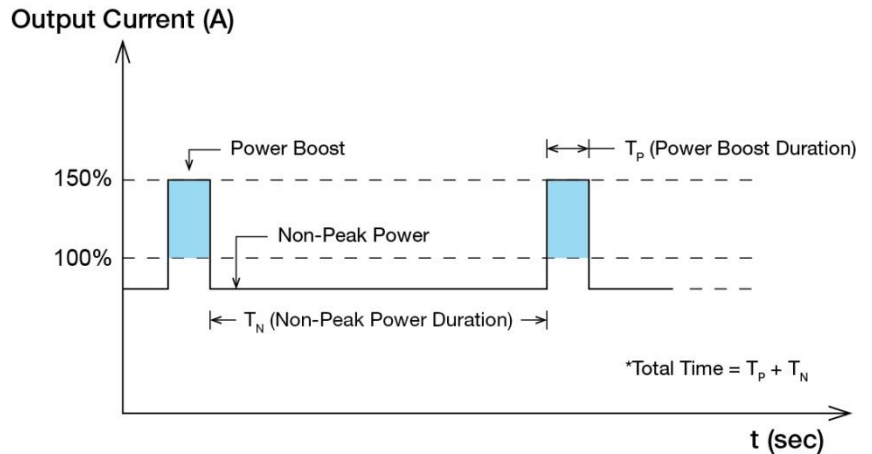

Fig. 4 Duty Cycle Calculation

$$\text{Duty cycle (\%)} = \frac{T_p}{\text{Total Time}}; (T_p \leq 5 \text{ sec})$$

$$\text{Average Output Power (} P_{Avg} \text{)} = \frac{(\text{Power Boost} \times T_p) + (\text{Non-Peak Power} \times T_N)}{\text{Total Time}}$$

or

$$\text{Non-Peak Power} = \frac{(P_{Avg} \times \text{Total Time}) - (\text{Power Boost} \times T_p)}{T_N}$$

#### ■ An example of Power Boost and Average Output Power

Power Boost	Peak Power (W <sub>P</sub> )	Power Boost Duration (T <sub>P</sub> )	Duty Cycle	Non-Peak Power (W <sub>N</sub> )	Non-Peak Power Duration (T <sub>N</sub> )	Total Time (T)
150%	1440W	5 sec	12.5%	891.43W	35 sec	40 sec

# LYTE II Series DIN Rail Power Supply

## DRL-960W Series / DRL-□V960W1EN□

■ Graph illustrating the Start-up Time, Rise Time, and Hold-up Time

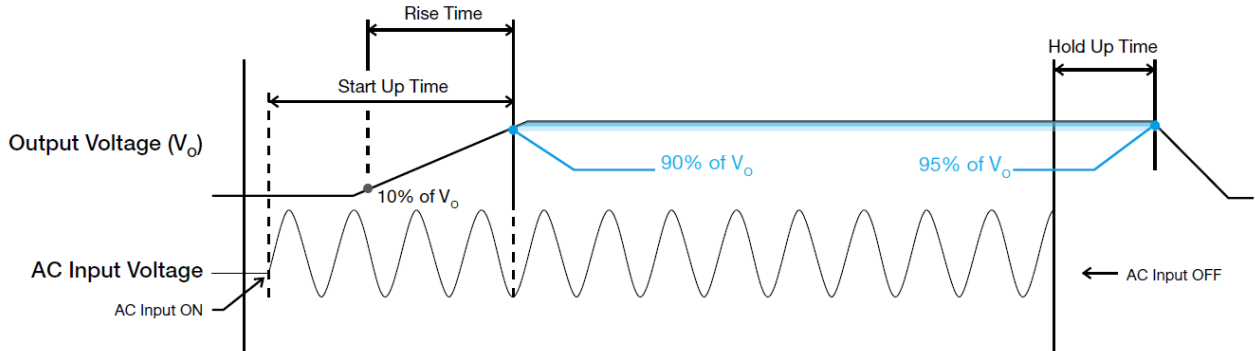

### Start-up Time

The time required for the output voltage to reach 90% of its final steady state set value, after the input voltage is applied.

### Rise Time

The time required for the output voltage to change from 10% to 90% of its final steady state set value.

### Hold-up Time

Time between the collapse of the AC input voltage, and the output falling to 95% of its steady state set value.

### Inrush Current

Inrush current is the peak, instantaneous, input current measured and, occurs when the input voltage is first applied. For AC input voltages, the maximum peak value of inrush current will occur during the first half cycle of the applied AC voltage. This peak value decreases exponentially during subsequent cycles of AC voltage.

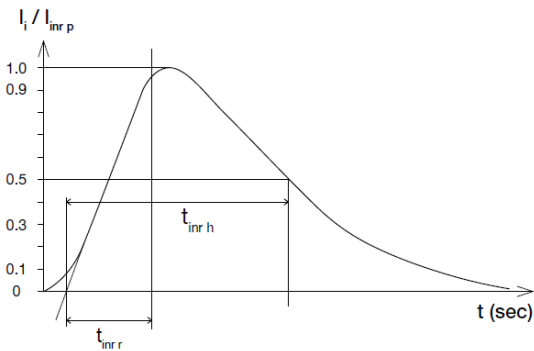

### Dynamic Response

The power supply output voltage will remain within  $\pm 10\%$  of its steady state value, when subjected to a dynamic load from 10% to 100% of its rated current.

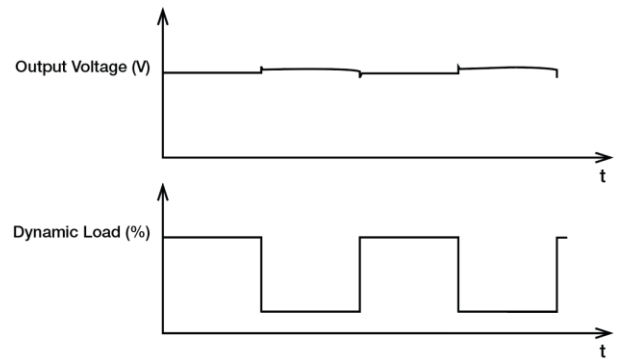

# LYTE II Series DIN Rail Power Supply

## DRL-960W Series / DRL-□V960W1EN□

### Overload & Overcurrent Protections (Auto-recovery)

The power supply's Overload (OLP) and Overcurrent (OCP) Protections will be monitored by internal counter when output current ( $I_o$ ) is 125~205% of maximum rated load ( $I_o$  Max). After counter reaches the limit value (typically 5s), output current will be limited to 150% typ. (refer to ① below) and output voltage ( $V_o$ ) will start to droop. Once  $V_o$  is below approximately area, the power supply will start to operate in "Hiccup mode" as described in short circuit protection. The power supply will recover once the fault condition due to OLP or OCP is removed, then  $I_o$  is back within its specified limits.

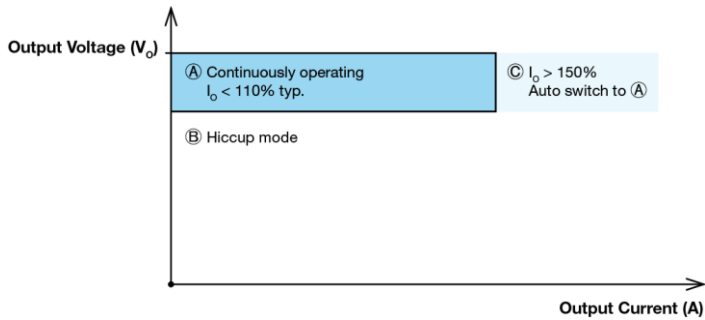

### Overvoltage Protection (Auto-recovery)

The power supply's overvoltage circuit will be activated when its internal feedback circuit fails. The output voltage shall not exceed its specifications defined on Page 4 under "Protections".

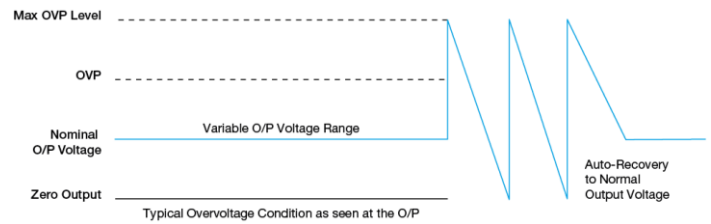

### Short Circuit Protection (Auto-recovery)

The power supply's output Short Circuit Protection function also provides protection against short circuits. When a short circuit is applied, the output current will operate in "Hiccup mode". The power supply will return to normal operation after the short circuit is removed.

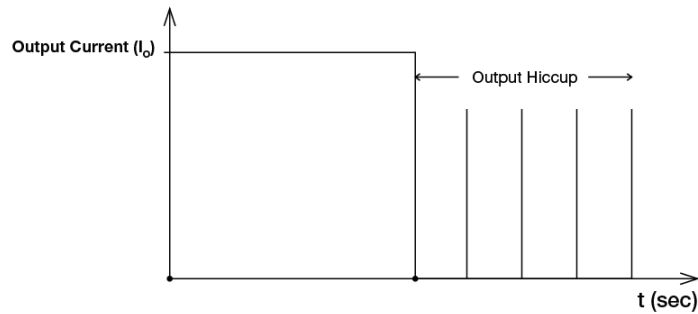

### Over Temperature Protection (Auto-recovery)

As described in load de-rating section, the power supply also has Over Temperature Protection (OTP). In the event of a higher operating temperature at 100% load; or, when the operating temperature is beyond what is recommended in the de-rating graph, the OTP circuit will be activated. When activated, power supply will latch off, until the surrounding air temperature drops to its normal operating temperature or the load is reduced as recommended in the de-rating graph. Removal/re-application of input AC voltage will then be required in order to restart.

# LYTE II Series DIN Rail Power Supply

## DRL-960W Series / DRL-□V960W1EN□

### Operating Connection

#### DC Input Operation

- DC input voltage range 100-400 Vdc

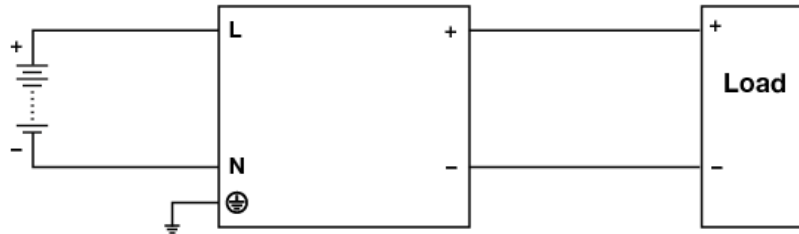

Fig. 5 DC Input Operation Connection Diagram

#### Step 1.

Use a battery or similar DC source.

#### Step 2.

Connect +pole to L and -pole to N.

#### Step 3.

Connect the PE terminal to an earth wire or to the machine ground.

### Others

#### Attention

Delta provides all information in the datasheets on an "AS IS" basis and does not offer any kind of warranty through the information for using the product. In the event of any discrepancy between the information in the catalog and datasheets, the datasheets shall prevail (please refer to [PSU.deltaww.com](http://PSU.deltaww.com) for the latest datasheets information). Delta shall have no liability of indemnification for any claim or action arising from any error for the provided information in the datasheets. Customer shall take its responsibility for evaluation of using the product before placing an order with Delta.

Delta reserves the right to make changes to the information described in the datasheets without notice.

### Manufacturer and Authorized Representatives Information

#### Manufacturer

##### Thailand

Delta Electronics (Thailand) PCL.  
909 Pattana 1 Rd., Muang, Samutprakarn, 10280 Thailand

##### Taiwan

Delta Electronics, Inc.  
3 Tungyuan Road, Chungli Industrial Zone, Taoyuan County  
32063, Taiwan

#### Authorized Representatives

##### The Netherlands

Delta Greentech (Netherlands) B.V.  
Zandsteen 15, 2132 MZ Hoofddorp, The Netherlands

##### United Kingdom

Delta Electronics Europe Limited  
1 Redwood Court, Peel Park Campus,  
East Kilbride, Glasgow, G74 5PF, United Kingdom