

- ALWAYS switch mains OFF before connecting and disconnecting the input/output to the LED driver, If mains are not turned OFF, there is a risk of damage.
- To ensure sufficient convection cooling, keep a distance of 80 mm above and lateral distance to nearby objects. For the proper installation orientation, refer to the figure on the below.
- The LED driver must not be mounted in areas that are prone to water or snow accumulation to avoid irreparable damage.
- The LED driver should not be mounted on low thermal conductivity surface such as plastic.
- DO NOT insert any objects into the LED driver.
- Note that the enclosure of the LED driver can be very hot depending on the surrounding ambient temperature and output load connected to the driver.
- When the PE of the LED driver is not connected, the driver must be installed on a grounded metal surface.
- The current rating of all wires connected to the LED driver's input and output should meet or exceed the driver's input and output current.
- Please ensure the correct tools are used for all adjustments and installations of the LED driver. If in doubt, please consult your local Delta support or contact us via info@DeltaPSU.com.

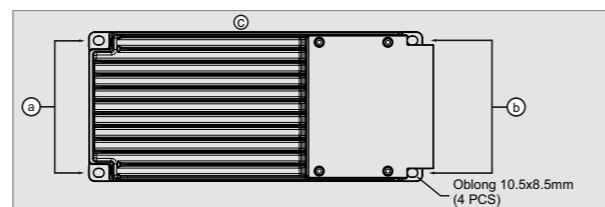

The LED driver features two mounting holes, one at each end of the driver. M8 screws with a minimum length of 12mm must be used for mounting. If customer's end system or panel is not pre-threaded, suitable metal screws and nuts must be used to secure the driver. (Location Ⓐ and Ⓑ) Surface Ⓒ is the LED driver's mounting surface within the customer's end product, the driver should be mounted on a sturdy surface with high thermal conductivity (e.g. metal), utilizing all four mounting holes.

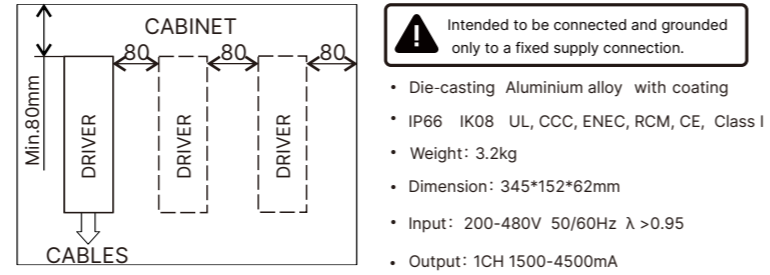
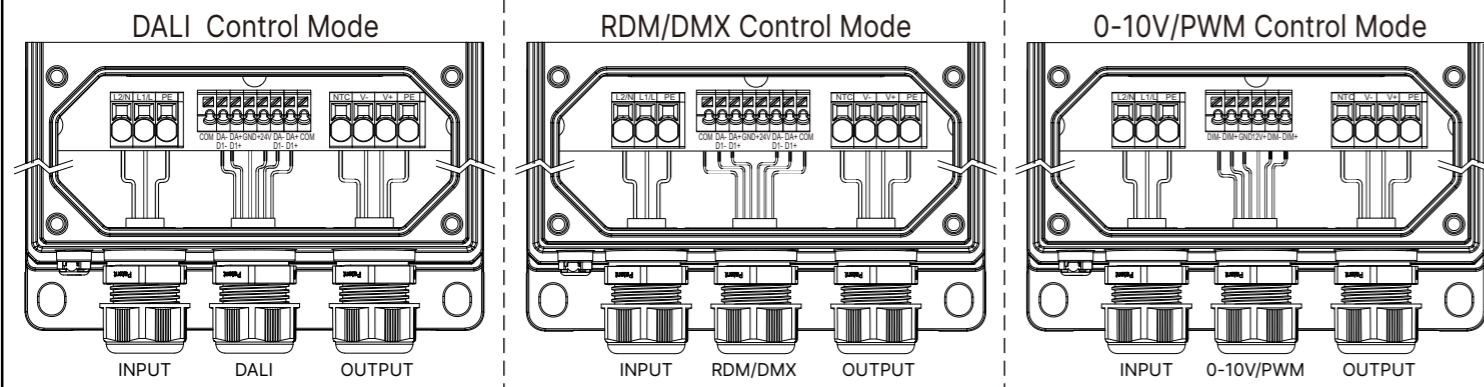

- The wiring must be connected strictly according to the label instructions, otherwise the product may be damaged or its functions impaired.
- The "+" and "-" terminals have opposite polarities and must not be cross connected.
- For connection use wire rated for at least 75°C.

LNA-1K8A45ABHGB			LNA-1K8A45ABFCB					
DALI Control			RDM/DMX Control			0~10V/PWM Control		
NO.	Marker	Description	NO.	Marker	Description	NO.	Marker	Description
4	COM	NC	4	COM	DMX Common port/Shielding	4	N/A	N/A
5	DA-/D1-	DALI in-	5	DA-/D1-	DMX in-	5	DIM-	DIM in-
6	DA+/D1+	DALI in+	6	DA+/D1+	DMX in+	6	DIM+	DIM in+
7	GND	Ground of "+24V"	7	GND	NC	7	GND	Ground of "12V"
8	+24V	+24V/3W auxiliary power supply	8	+24V	NC	8	12V+	12V/3W auxiliary power supply
9	DA-/D1-	DALI out-	9	DA-/D1-	DMX out-	9	DIM-	DIM out-
10	DA+/D1+	DALI out+	10	DA+/D1+	DMX out+	10	DIM+	DIM out+
11	COM	NC	11	COM	DMX Common port/Shielding	11	N/A	N/A

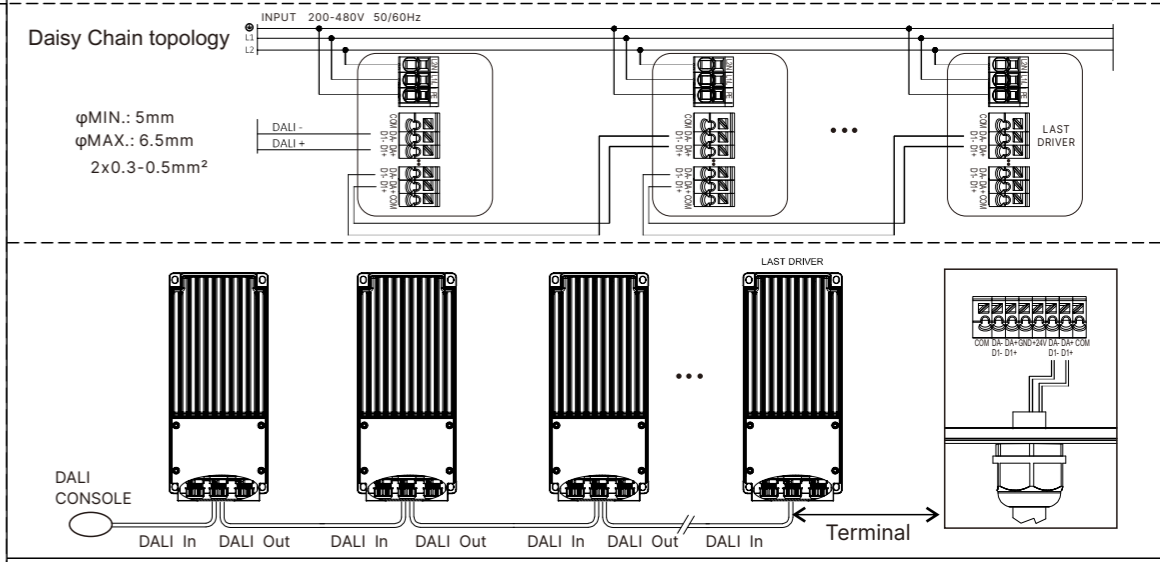
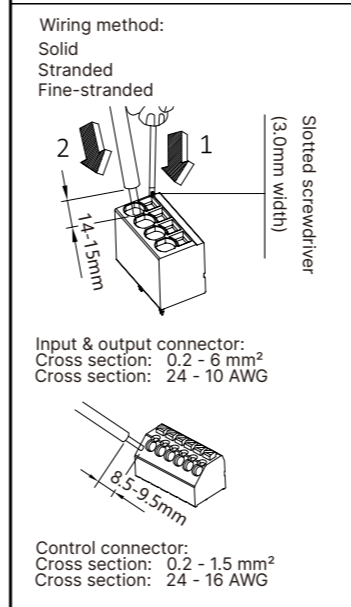
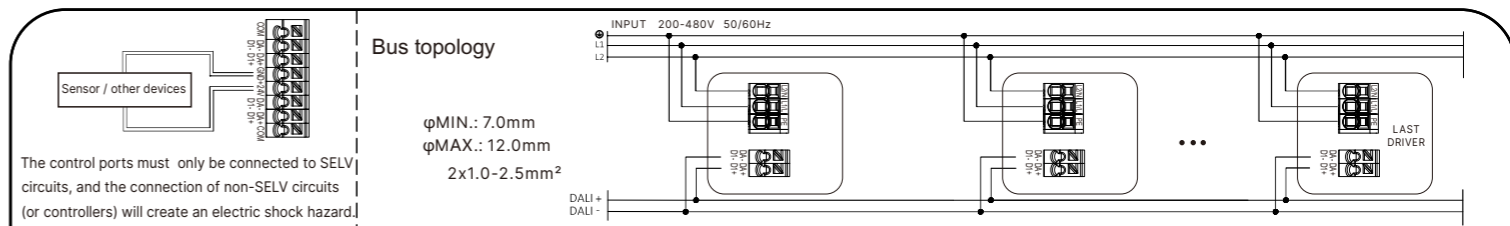
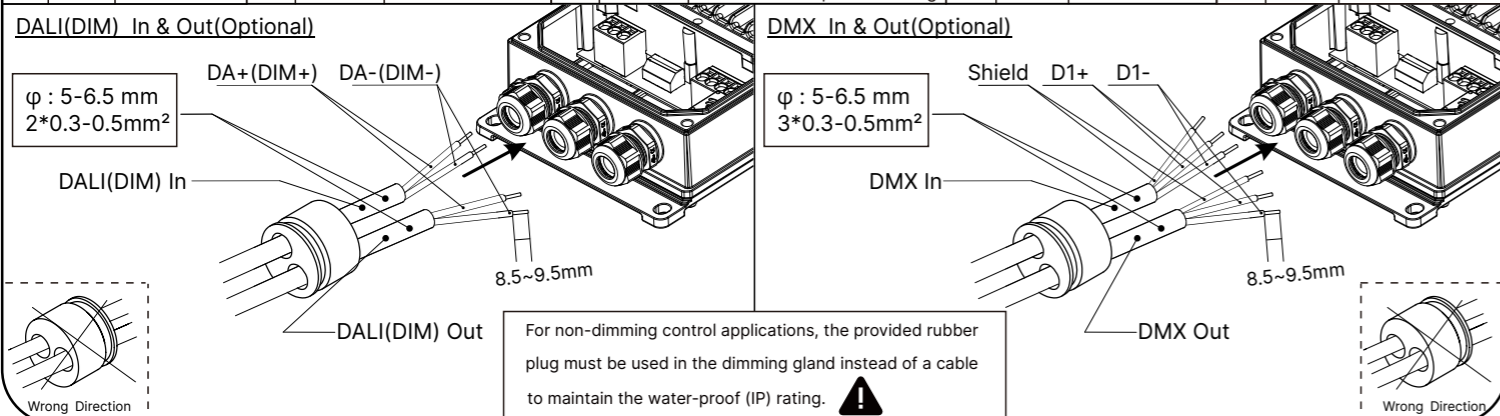

- Points for attention about RDM/DMX version:**
- DMX is a three-wire system. Use all three!
 - DMX is based on the EIA-485/RS-485 standard
 - Always use cable specifically designed for DMX / RS-485. For instance: Belden 9841 or 3105a
 - DMX must be terminated with a 120 Ω resistor to prevent reflections.
 - A daisy chain topology should be used.
 - After 32 unit loads a repeater/booster should be used.
 - Keep cabling below 300 metres between the controller and the last driver

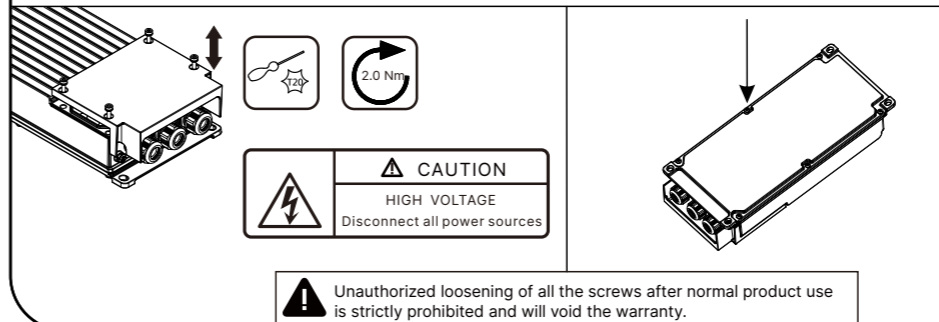
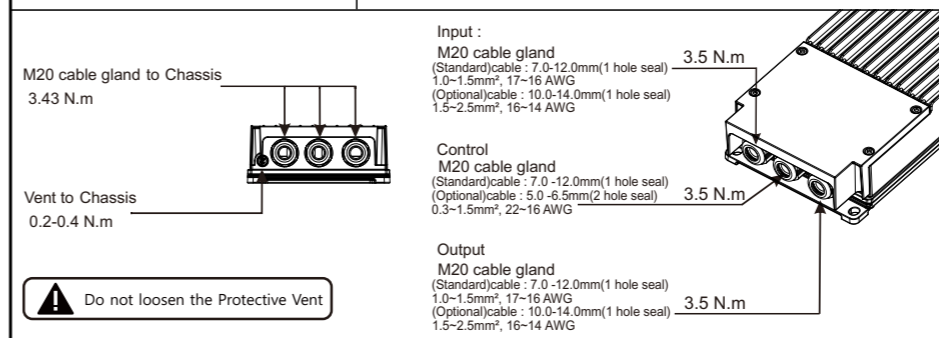
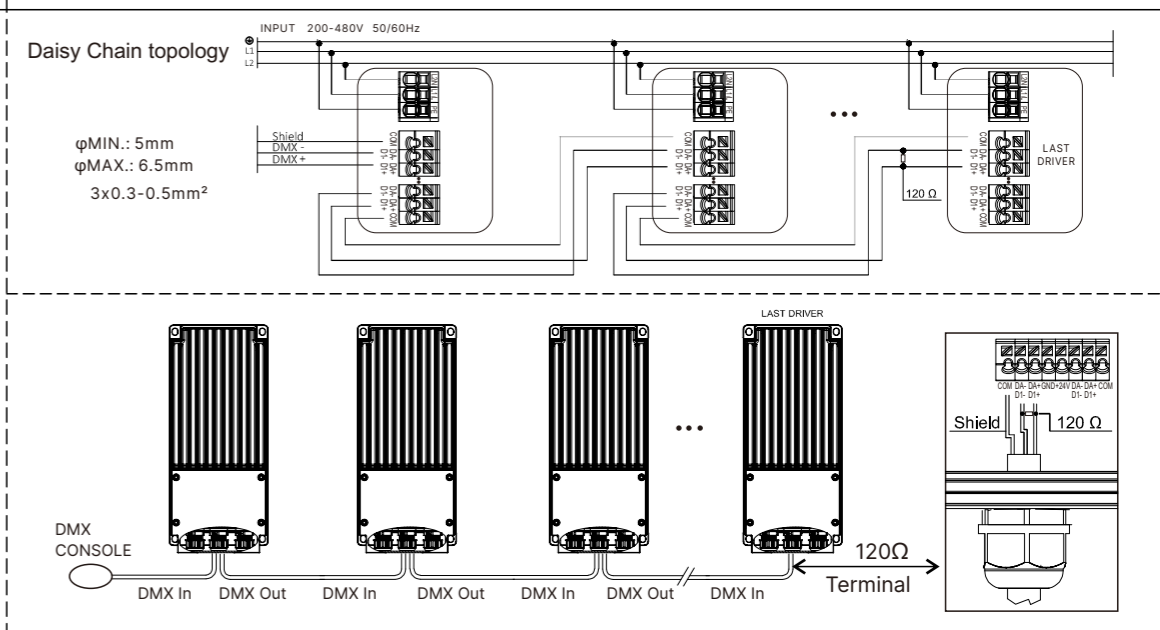

Authorized representative:
Delta Electronics (Netherlands) B.V.
Zandsteen 15, 2132 MZ Hoofddorp, The Netherlands

Application models:
LNA-1K8A45ABFCB; LNA-1K8A45ABHGB;
LNA-1K2A45ABFCB; LNA-1K2A45ABHGB;

