

# DIN Pro Series DIN Rail Power Supply

## DRF-120W Series / DRF-□V120W1PBA

# DIN Pro



### Highlights & Features

- Wide AC input voltage range 85-277 V (305 V / 60 s)
- Power Boost up to 150% for 5 seconds
- Full load operating temperature up to 60°C
- Wide operating temperature range from -40 to 80°C
- Built-in DC OK relay and LED indicator
- Built-in remote ON / OFF control
- Meet IEC 61000-4-6 CS 20V rms
- Slim profile design
- Conformal coating on PCBAs to protect against common dust and pollutants
- IEC/EN/UL 62368, IEC/UL 61010, and IEC 61558 certified
- Compliant with SEMI F47 standard

### Safety Standards



CB Certified for worldwide use

**Model Number:** DRF-□V120W1PBA  
**Unit Weight:** 0.50 kg (1.10 lb)  
**Dimensions (H x W x D):** 124.2 x 30.0 x 117.1 mm  
 (4.89 x 1.18 x 4.61 inch)

### General Description

Delta's DIN Pro Series DIN rail power supply features high power density and high efficiency. Other key features are the conformal coating on the PCBA and a 150% Power Boost for up to 5 seconds to meet the demands of inductive and capacitive load applications. The products are designed according to major industrial and electrical measurement category safety standards. In addition, the Series' radiated and conducted electromagnetic emissions comply with heavy industrial Class B Emission and Immunity standards, as well as the IEC 61000-4-6 CS (Conducted Susceptibility) with a 20V rms criterion. Other built-in features include DC OK contacts, an LED indicator for DC OK status, also remote ON/OFF control to integrate into a system control. The products also meet environmental protection requirements in accordance with the RoHS and REACH directives.

### Model Information

DIN Pro Series DIN Rail Power Supply

Model Number	Input Voltage Range	Rated Output Voltage	Rated Output Current
DRF-12V120W1PBA	85-277 Vac (100-400 Vdc)	12 Vdc	10.0 A
DRF-24V120W1PBA		24 Vdc	5.0 A
DRF-48V120W1PBA		48 Vdc	2.5 A

### Model Numbering

DR	F –	□V	120W	1	P	B	A
DIN Rail	Product Series F – DIN Pro	Output Voltage 12 – 12 V 24 – 24 V 48 – 48 V	Output Power	Single Phase	P – Power Boost	Connector Type B – Screw Terminal	Delta Standard (with Conformal Coating)



# DIN Pro Series DIN Rail Power Supply

## DRF-120W Series / DRF-□V120W1PBA

### Specifications

Model Number	DRF-12V120W1PBA	DRF-24V120W1PBA	DRF-48V120W1PBA
--------------	-----------------	-----------------	-----------------

### Input Ratings / Characteristics\*1

Nominal Input Voltage	100-240 Vac		
Input Voltage Range	85-277 Vac (305 Vac available for 60 seconds)		
Nominal Input Frequency	50-60 Hz		
Input Frequency Range	47-63 Hz		
DC Input Voltage Range*2	100-400 Vdc (Please refer to page 8 derating curve)		
Input Current	1.2 A typ. @ 115 Vac, 0.6 A typ. @ 230 Vac		
Efficiency at 100% Load	92.5% typ. @ 230 Vac	92.5% typ. @ 230 Vac	91.5% typ. @ 230 Vac
No Load Power Consumption	1.1 W max @ 115 Vac & 230 Vac		2.3 W max @ 115 Vac & 230 Vac
Max Inrush Current (Cold Start)	40 A typ. @ 230 Vac		
Power Factor at 100% Load	> 0.98 @ 115 Vac & > 0.95 @ 230 Vac		
Leakage Current	< 0.5 mA @ 230 Vac		

\*1 All parameters not specially mentioned are measured at 230 Vac input and 25°C ambient temperature.

\*2 Power Supply can operate at DC input voltage, please connect +pole to L, -pole to N and PE terminal to an earth wire or to the machine ground.

### Output Ratings / Characteristics

Nominal Output Voltage	12 Vdc	24 Vdc	48 Vdc
Factory Set Point Tolerance	12 Vdc ± 1%	24 Vdc ± 1%	48 Vdc ± 1%
Output Voltage Adjustment Range	12-15 Vdc	24-29 Vdc	48-56 Vdc
Output Current	0-10.0 A	0-5.0 A	0-2.5 A
Output Power	120 W max		
Line Regulation	± 0.5% @ 115 Vac & 230 Vac		
Load Regulation	± 1.0%	± 0.5%	
PARD*3 (20 MHz)	< 100 mVpp @ 0°C to +70°C < 300 mVpp @ -30°C to 0°C		< 120 mVpp @ 0°C to +70°C < 360 mVpp @ -30°C to 0°C
Rise Time	30 ms typ. @ 115 Vac & 230 Vac		
Start-up Time	300 ms typ. @ 115 Vac & 230 Vac		
Hold-up Time	40 ms typ. @ 115 Vac & 230 Vac (100% load)		
Dynamic Response (Overshoot & Undershoot O/P Voltage)	± 10% @ 115 Vac & 230 Vac input, 10-100% load (Slew Rate: 2.5 A/μS, 50% duty cycle @ 5 Hz & 10 kHz)		
Start-up with Capacitive Loads	10,000 μF Max		4,000 μF Max
Functional	DC OK Relay Contact	30 V / 1 A The relay contact are normally "ON" (closed) when the output (Vout) is greater than 90% typ. of its rated value.	
	Remote Control	Remotely control the power supply unit to turn ON/OFF by using an external DC source for power "ON" with 0~0.5V, power "OFF" with 5V~12.5V.	

\*3 PARD is measured with an AC coupling mode, 5cm wires, and in parallel to end terminal with 0.1 μF ceramic capacitor & 47 μF electrolytic capacitor. PSU need to burn in around 5 minutes when ambient temperature ≤ 0°C.

# DIN Pro Series DIN Rail Power Supply

## DRF-120W Series / DRF-□V120W1PBA

Model Number	DRF-12V120W1PBA	DRF-24V120W1PBA	DRF-48V120W1PBA
--------------	-----------------	-----------------	-----------------

### Mechanical

Cover	Galvanized steel with organic coating		
Chassis	Aluminum alloy with organic coating		
Dimensions (H x W x D)	124.2 x 30.0 x 117.1 mm (4.89 x 1.18 x 4.61 inch)		
Unit Weight	0.50 kg (1.10 lb)		
Indicator	Green LED	DC OK	
Cooling System	Convection		
Terminal*4	Input	3 Pins (Rated 600 V / 30 A)	
	Output	3 Pins (Rated 600 V / 30 A)	
	DC OK & Remote	4 Pins (Rated 300 V / 7 A)	
Wire	Input	AWG 18-10	
	Output	AWG 16-10	
	DC OK & Remote	AWG 22-18	
Mounting Rail	Standard TS35 DIN Rail in accordance with EN 60715		
Noise (1 Meter from power supply)	Sound Pressure Level (SPL) < 25 dBA		

\*4 The torque at the screw terminal connector shall not exceed 8.0 Kgf.cm. (7.0 lbf.in).

### Environment

Surrounding Air Temperature*5/6	Operating	-40°C to +80°C (Please refer to page 8 derating curve)
	Storage	-40°C to +85°C
Power De-rating	Temperature	> 60°C de-rate power by 2.5 % / °C, > 70°C de-rate power by 3.5% / °C
	Input Voltage	< 100 Vac de-rate power by 1% / Vac < 200 Vdc de-rate power by 0.3% / Vdc
Operating Humidity	5 to 90% RH (Non-Condensing)	
Operating Altitude	0 to 5,000 Meters (16,400 ft.)	
Shock Test	Non-Operating	IEC 60068-2-27, Half Sine Wave: 50 G for duration of 11 ms; 3 times per direction, 9 times in total
Vibration	Non-Operating	IEC 60068-2-64, Random: 5 Hz to 500 Hz (2.09 G); 20 min per axis for all X, Y, Z direction
	Operating	IEC 60068-2-6, Sine Wave: 10 Hz to 500 Hz (2G peak); 10 min per cycle, 60 min for X, Y, Z direction
Over Voltage Category	II (Compliance to EN 61558-1 OVC III with 2000 meters altitude)	
Pollution Degree	2	

\*5 When operating at temperatures below -30°C, the PSU may require a few seconds to “bounce” before completing a cold-start power-up.

\*6 For power de-rating from 60°C to 80°C, refer power derating on page 8.

# DIN Pro Series DIN Rail Power Supply

## DRF-120W Series / DRF-□V120W1PBA

Model Number	DRF-12V120W1PBA	DRF-24V120W1PBA	DRF-48V120W1PBA
--------------	-----------------	-----------------	-----------------

### Protections

Overvoltage	<19 V, SELV Output, Hiccup Mode, Auto-recovery	<37 V, SELV Output, Hiccup Mode, Auto-recovery	<69 V, SELV Output, Hiccup Mode, Auto-recovery
Overload / Overcurrent	125 - 205% of rated load current, Hiccup Mode, Auto-recovery (150% Power Boost for 5 seconds / 200% for 50ms / 500% for 5ms)		
Over Temperature	Shut down, Auto-recovery		
Short Circuit	Hiccup Mode, Non-Latching (Auto-Recovery when the fault is removed)		
Protection Against Shock	Class I with PE <sup>*7</sup> connection		

\*7 PE: Primary Earth

### Reliability Data

MTBF	Telcordia SR-332	> 700,000 hrs I/P: 115 Vac & 230 Vac, O/P: 100% load, Ta: 25°C
Expected Cap Life Time	10 Years (115 Vac & 230 Vac, 50% load @ 50°C) 5 Years (230 Vac, 80% load @ 50°C)	
Warranty	5 Years	

### Safety Standards / Directives

Electrical Safety	CB scheme	IEC/EN/BS EN 62368-1, AS/NZS 62368-1 RCM, IEC/EN 61010-1/2-201, IEC 61558-1/2-16, AS/NZS 61558-1/2-16 RCM
	TUV Bauart	EN 62368-1
	UL/cUL	UL 62368-1, CSA C22.2; UL 61010-1/-2-201, CAN/CSA-C22.2 No. 61010-1-12
	CCC	GB4943.1
	BIS	IS 13252-1 (Part 1)
	BSMI	CNS 15598-1
	EAC	TP TC 004/2011
	KC	KC 62368-1 (upon request)
CE	In conformance with EMC Directive 2014/30/EU and Low Voltage Directive 2014/35/EU	
UKCA	In conformance with Electrical Equipment (Safety) Regulations 2016 No. 1011 and The Electromagnetic Compatibility Regulations 2016 No. 1091	
SELV	IEC/EN 62368-1 /61010-2-201 /61558-2-16	
Galvanic Isolation	Input to Output	4.0 kVac
	Input to Ground	2.5 kVac
	Output to Ground	1.5 kVac
	Output to DC OK	500 Vac

# DIN Pro Series DIN Rail Power Supply

## DRF-120W Series / DRF-□V120W1PBA

Model Number	DRF-12V120W1PBA	DRF-24V120W1PBA	DRF-48V120W1PBA
--------------	-----------------	-----------------	-----------------

### EMC<sup>\*8</sup>

Emissions (CE & RE)	CISPR 32, EN/BS EN 55032, AS/NZS CISPR 32, Class B; KS C 9832; CNS15936; EN/BS EN 61204-3; Compliance to FCC Title 47		
Immunity	EN/BS EN 55035; KS C 9835; EN/BS EN 61204-3		
Electrostatic Discharge	IEC 61000-4-2	Level 4 Criteria A <sup>1)</sup> Air Discharge: 15 kV Contact Discharge: 8 kV	
Radiated Field	IEC 61000-4-3	Criteria A <sup>1)</sup> 80 MHz – 1 GHz, 10 V/M, 80% Modulation (1 kHz) 1.4 GHz – 6 GHz, 3 V/M, 80% Modulation (1 kHz) 2 GHz – 2.7 GHz, 1 V/M, 80% Modulation (1 kHz)	
Electrical Fast Transient / Burst	IEC 61000-4-4	Level 3 Criteria A <sup>1)</sup> 4 kV	
Surge	IEC 61000-4-5	Level 4 Criteria A <sup>1)</sup>	
		Condition	W/O SPD
		Common Mode <sup>4)</sup>	4 kV
		Differential Mode <sup>5)</sup>	2 kV
Conducted	IEC 61000-4-6	Level 3 Criteria A <sup>1)</sup> 150 kHz – 80 MHz, 20 Vrms	
Power Frequency Magnetic Fields	IEC 61000-4-8	Level 4 Criteria A <sup>1)</sup> 30 A/m	
Voltage Dips and Interruptions	IEC 61000-4-11	0% residual; 1 cycle, Criteria B <sup>2)</sup> 40% residual; 10 cycle, Criteria B <sup>3)</sup> 70% residual; 25 cycle, Criteria B <sup>3)</sup>	
Harmonic Current Emission	IEC/EN/BS EN 61000-3-2, Class A		
Voltage Fluctuation and Flicker	IEC/EN/BS EN 61000-3-3, dmax ≤ 4%		
Voltage Sag Immunity SEMI F47 – 0706	80% of 200 Vac	160 Vac, 1000 ms	Criteria A <sup>1)</sup>
	70% of 200 Vac	140 Vac, 500 ms	Criteria A <sup>1)</sup>
	50% of 200 Vac	100 Vac, 200 ms	Criteria A <sup>1)</sup>

1) Criteria A: Normal performance within the specification limits

2) Criteria B: Temporary degradation or loss of function which is self-recoverable

3) Criteria C: Output out of regulation, shuts down during test (Need to recycle AC power cord to normal operation after test)

4) Asymmetrical: Common mode (Line to earth)

5) Symmetrical: Differential mode (Line to line)

\*8 Power supply is considered a component in the end-user's system. Please contact our local sales to get more information about the power supply EMC test setup.

# DIN Pro Series DIN Rail Power Supply

## DRF-120W Series / DRF-□V120W1PBA

### Block Diagram

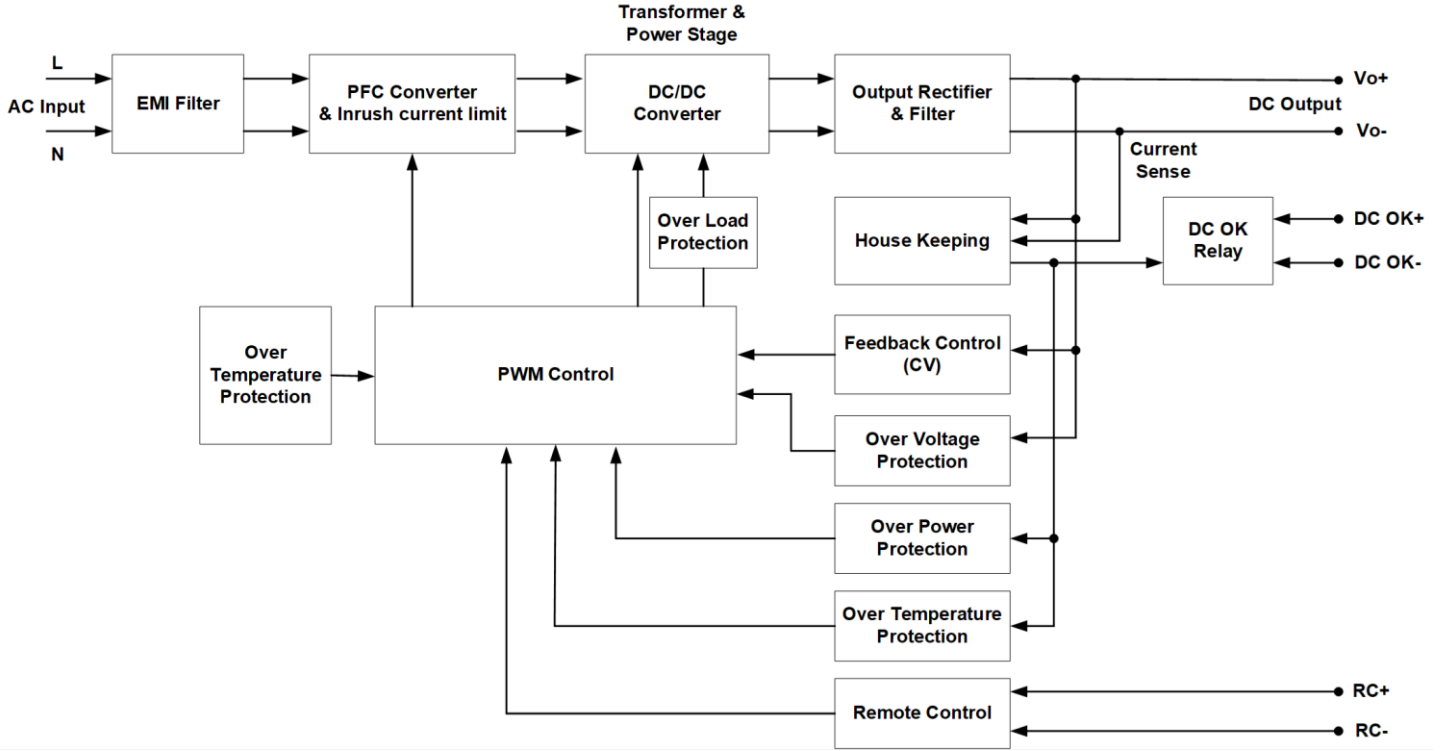

### Device Description

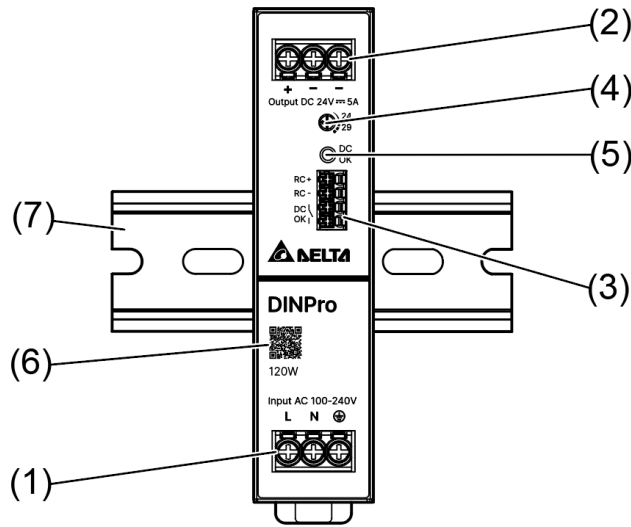

- 1) Input terminal block connector
- 2) Output terminal block connector
- 3) Remote ON/OFF and DC OK relay contact
- 4) DC voltage adjustment potentiometer
- 5) DC OK LED (Green)
- 6) QR code for product datasheet link
- 7) Universal mounting rail system

# DIN Pro Series DIN Rail Power Supply

## DRF-120W Series / DRF-□V120W1PBA

### Dimensions

H x W x D: 124.2 x 30.0 x 117.1 mm (4.89 x 1.18 x 4.61 inch)

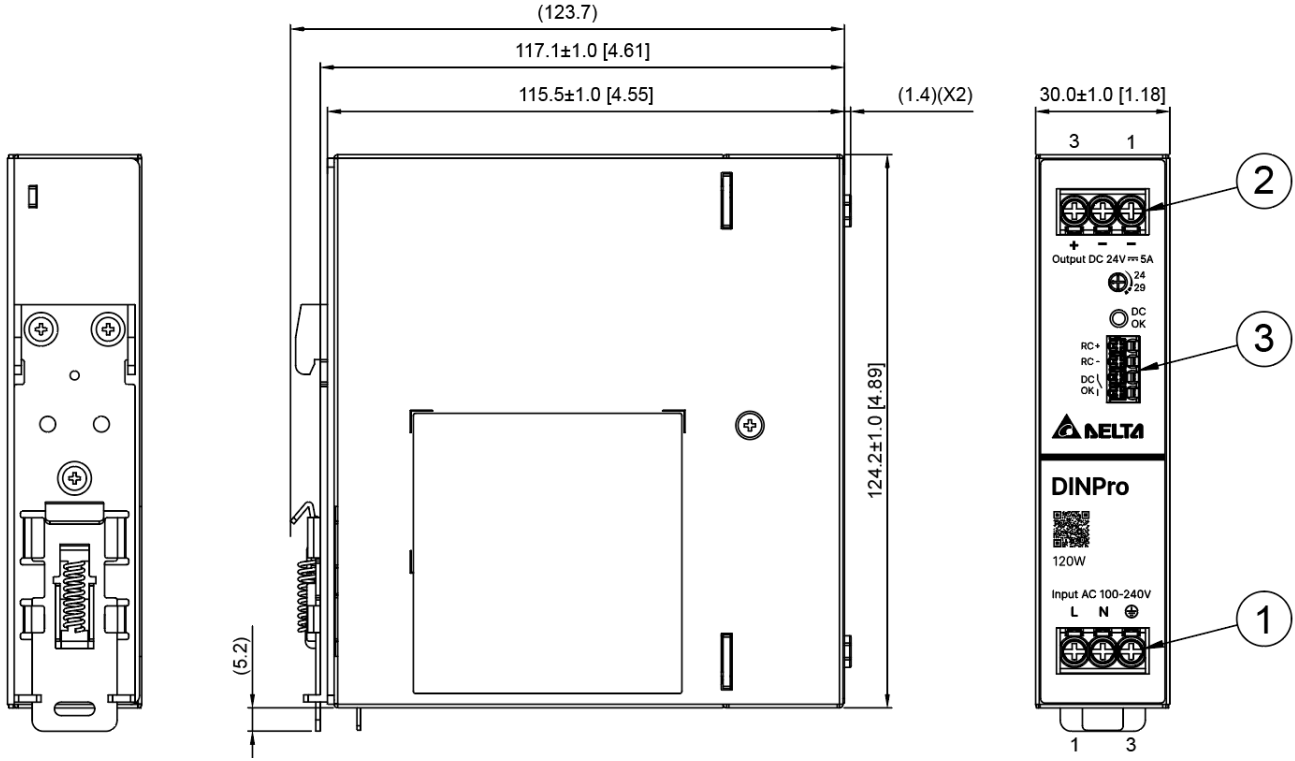

Item	Device Description
1	Input terminal block connector Pin 1: L Pin 2: N Pin 3: PE
2	Output terminal block connector Pin 1 to 2: V(-) Pin 3: V(+)
3	Remote ON/OFF and DC OK relay contact Pin 1: RC + Pin 2: RC - Pin 3: DC OK + Pin 4: DC OK -

### Wiring Size:

	Stranded / Solid		Torque		Stripping Length (mm)
	(mm <sup>2</sup> )	(AWG)	(Kgf.cm)	(lbf.in)	
(1) Input	0.82-5.26	18-10	8.0	7.0	
(2) Output	1.30-5.26	16-10	8.0	7.0	
(3) Remote ON/OFF and DC OK relay contact	0.32-0.82	22-18	-	-	

# DIN Pro Series DIN Rail Power Supply

## DRF-120W Series / DRF-□V120W1PBA

### Engineering Data

#### Output Load De-rating VS Surrounding Air Temperature

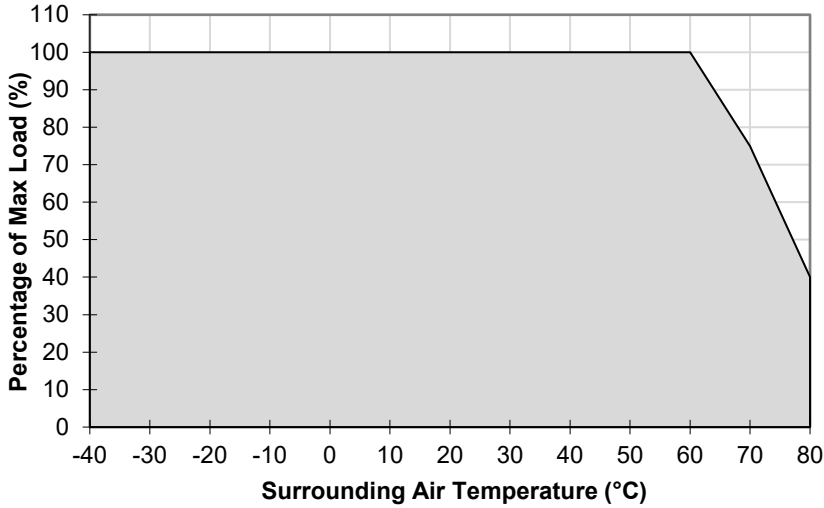

**Fig. 1 De-rating for Vertical Mounting Orientation**

> 60°C de-rate power by 2.5% / °C  
 > 70°C de-rate power by 3.5% / °C

Note: When operating at temperatures below -30°C, the PSU may require a few seconds to "bounce" before completing a cold-start power-up.

#### Note

1. Power supply components may degrade, or be damaged, when the power supply is continuously used outside the shaded region, refer to the graph shown in Fig. 1.
2. The power supply will have a longer rise time when the ambient temperature range is -30°C to -40°C.
3. If the output capacity is not reduced when the surrounding air temperature > 60°C, the device will run into Over Temperature Protection. When activated, power supply will latch off, until the surrounding air temperature is lowered or the load is reduced as far as necessary to keep the device in working condition, and require removal/re-application of input AC voltage in order to restart.
4. In order for the device to function in the manner intended, it is also necessary to keep a safety distance as recommended in the safety instructions while the device is in operation.
5. Depending on the surrounding air temperature and output load delivered by the power supply, the device can be very hot!
6. Need to consider power de-rating if Surrounding Air Temperature is > 60°C.
7. If the device has to be mounted in any other orientation, please leave a message via the [Contact Us](#) form.

#### Output Load De-rating VS Input Voltage

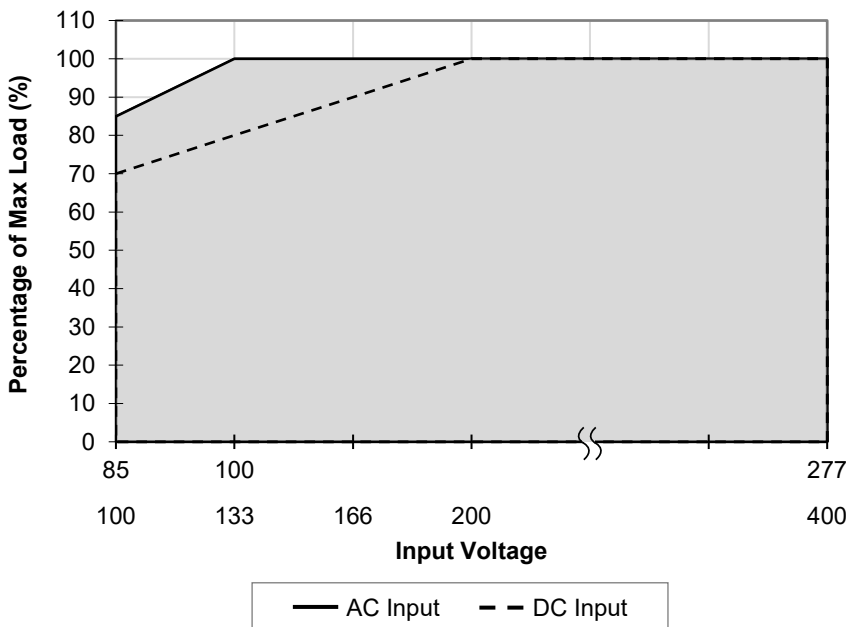

■ No output power de-rating for the input voltage from 100 Vac to 277 Vac & 200 Vdc to 400 Vdc

**Fig. 2 De-rating for AC & DC Input Voltage**

< 100 Vac de-rate power by 1% / Vac  
 < 200 Vdc de-rate power by 0.3% / Vdc

# DIN Pro Series DIN Rail Power Supply

## DRF-120W Series / DRF-□V120W1PBA

### Assembly & Installation

The power supply unit (PSU) can be mounted on 35 mm DIN rails in accordance with EN 60715. The device should be installed with input terminal block at the bottom.

Each device is delivered ready to install.

#### Mounting

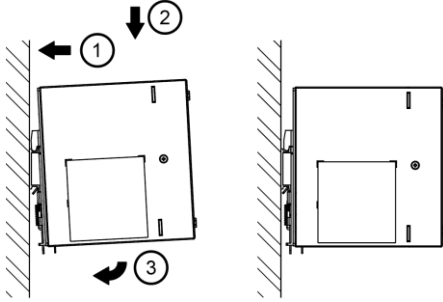

Fig. 3.1 Mounting

Snap on the DIN rail as shown in Fig. 3.1:

1. Tilt the unit upwards and insert it onto the DIN rail.
2. Push downwards until stopped.
3. Press against the bottom front side for locking.
4. Shake the unit slightly to ensure that it is secured

#### Dismounting

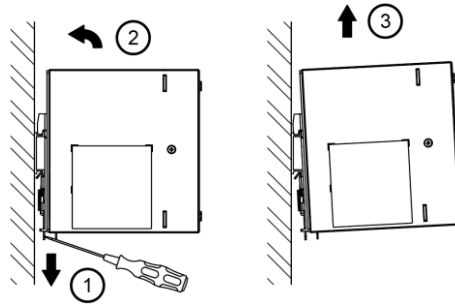
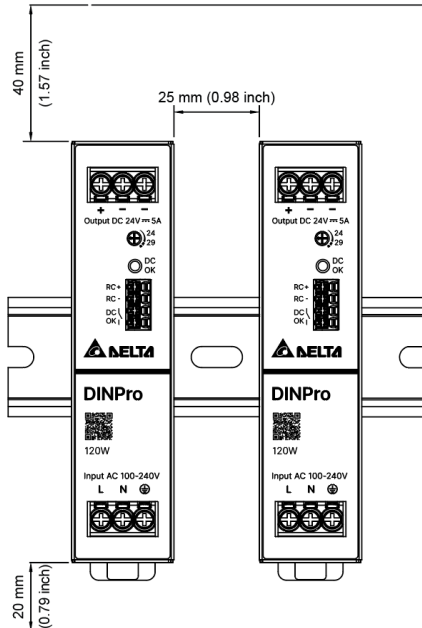

Fig. 3.2 Dismounting

To uninstall, Delta provides an easy way to pull or slide down the latch with screw driver as shown in Fig. 3.2. Then slide the power supply unit (PSU) in the opposite direction, release the latch and pull out the power supply unit (PSU) from the rail.

### Safety Instructions

#### Vertical Mounting



- ALWAYS switch mains of input power OFF before connecting and disconnecting the input voltage to the unit. If mains are not turned OFF, there is risk of explosion / severe damage.
- To guarantee sufficient convection cooling, keep a distance of 40 mm (1.57 inch) above and 20 mm (0.79 inch) below. If load is less than 50%, lateral distance can be 0 mm (0 in). In case the adjacent device is a heat source, the lateral distance will be 15 mm (0.59 in) for 80% load or > 25 mm (0.98 in) lateral distance condition for 100% load @ 60°C ambient temperature.
- Note that the enclosure of the device can become very hot depending on the surrounding air temperature and load of the power supply. Risk of burns!
- The main power must be turned off before connecting or disconnecting wires to the terminals.
- DO NOT insert any objects into the unit.
- Hazardous voltages may be present for up to 5 minutes after the input mains voltage is disconnected. Do not touch the unit during this time.
- The power supplies are built in units and must be installed in a cabinet or room (condensation free environment and indoor location) that is relatively free of conductive contaminants.
- For detailed product installation and notice, please refer the user manual.

# DIN Pro Series DIN Rail Power Supply

## DRF-120W Series / DRF-□V120W1PBA

### Functions

#### DC OK Relay Contacts and LED Indicator Characteristics

DC OK Relay Contacts Status	Characteristics
Contact closes	The output voltage > 90% typ. of its steady state set value.
Contact opens	The output voltage < 85% typ. of its steady state set value.

Operating Status	DC OK (Green LED)	DC OK Relay Contact
Normal Operation	ON	Closed
Overload (Hiccup Mode)	INTERMITTENT	INTERMITTENT
Output Short Circuit	INTERMITTENT	INTERMITTENT
Over Temperature	OFF	Open
No Input Power	OFF	Open
Over Voltage	Flash / 1 Hz	Closed

### Remote Control Function

Output ON/OFF remote control could be achieved through applying voltage to the remote ON/OFF connector. Connect an external DC power supply and apply the specified voltage below to control the output.

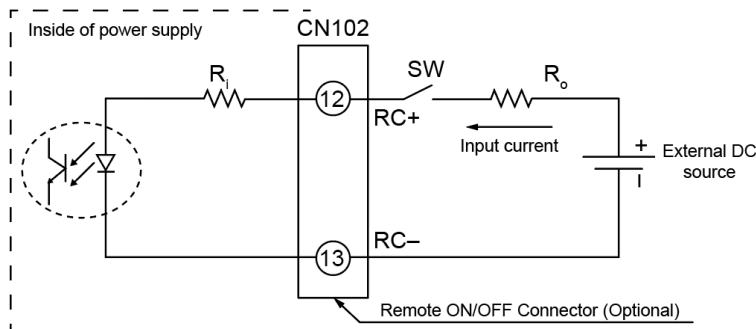

R <sub>i</sub>	External DC Source		Input Current
	Output ON	Output OFF	
1.5KΩ	0V-0.5V	5V-12.5V	20mA max.

### Notes

1. Remote ON/OFF circuits are isolated from input, output and PE.
2. Please check if the polarity of the wire connector is the same as the external DC source. If not, the power would not turn on and the internal components may be damaged.
3. You do not need an external resistance R<sub>o</sub> for current limit while the output voltage of external DC source is within the range of 5-12.5 V. If the output voltage exceeds 12.5 V, please use the following equation for the value of current limit resistance R<sub>o</sub>.

$$R_o = \frac{V_{cc} - (3.5 + 0.006R_i)}{0.006}$$

# DIN Pro Series DIN Rail Power Supply

## DRF-120W Series / DRF-□V120W1PBA

### Power Boost

Power Boost is the reserve power available constantly that allows reliable startup to support sudden and short spike of loads with high inrush current typically during turn on to remove the need of more expensive higher rated power supply unit. After the output has reached its steady state set value, the power supply can support surge loads with a higher short-term power demand up to 150% of maximum rated load (I<sub>o</sub> Max), for a maximum duration of 5 seconds. The Power Boost function can also be applied on a repetitive basis, provided that the average (RMS) output power does not exceed the continuous operating rating. Please refer to the duty cycle calculation below.

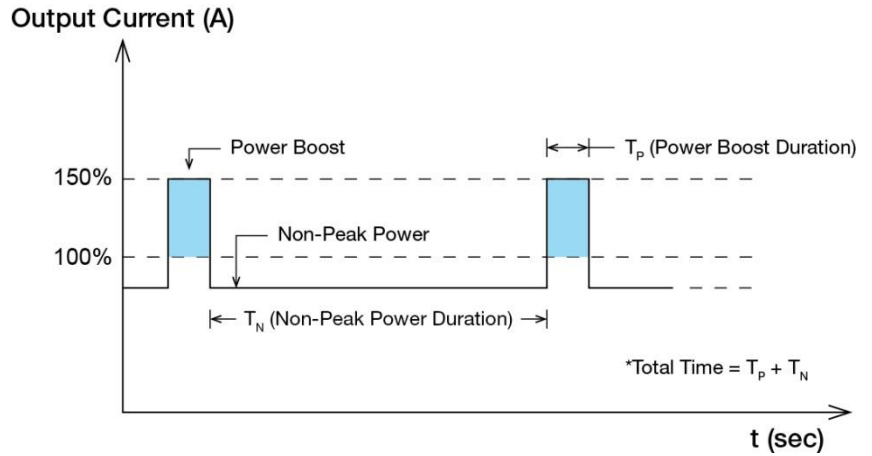

Fig. 4 Duty Cycle Calculation

$$\text{Duty cycle (\%)} = \frac{T_p}{\text{Total Time}}; (T_p \leq 5 \text{ sec})$$

$$\text{Average Output Power (P}_{Avg}\text{)} = \frac{(\text{Power Boost} \times T_p) + (\text{Non-Peak Power} \times T_N)}{\text{Total Time}}$$

OR

$$\text{Non-Peak Power} = \frac{(\text{P}_{Avg} \times \text{Total Time}) - (\text{Power Boost} \times T_p)}{T_N}$$

### ■ An example of Power Boost and Average Output Power

Power Boost	Peak Power (W <sub>P</sub> )	Power Boost Duration (T <sub>P</sub> )	Duty Cycle	Non-Peak Power (W <sub>N</sub> )	Non-Peak Power Duration (T <sub>N</sub> )	Total Time (T)
150%	180W	5 sec	14.3%	110W	30 sec	35 sec

# DIN Pro Series DIN Rail Power Supply

## DRF-120W Series / DRF-□V120W1PBA

■ Graph illustrating the Start-up Time, Rise Time, and Hold-up Time

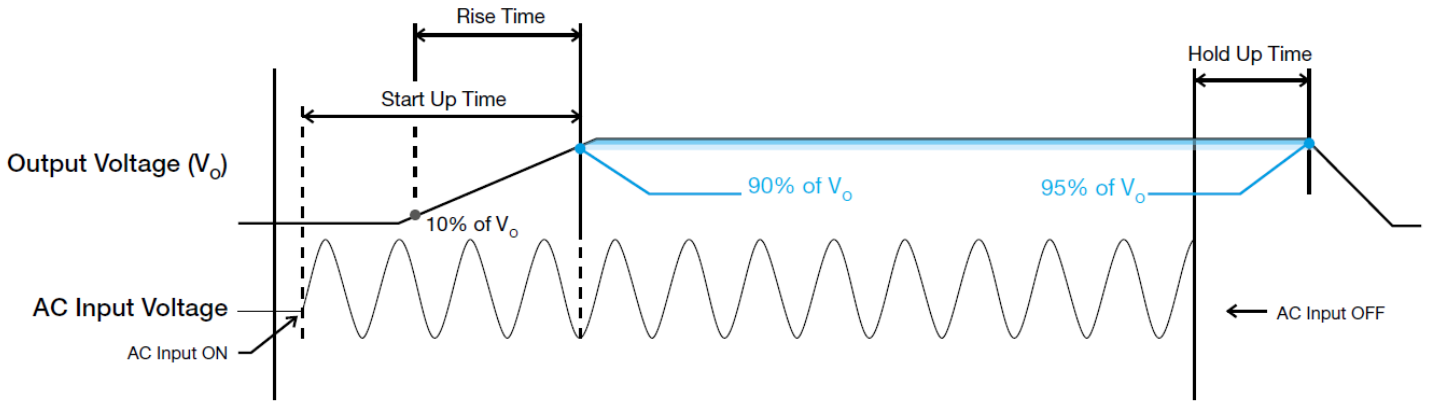

### Start-up Time

The time required for the output voltage to reach 90% of its final steady state set value, after the input voltage is applied.

### Rise Time

The time required for the output voltage to change from 10% to 90% of its final steady state set value.

### Hold-up Time

Time between the collapse of the AC input voltage, and the output falling to 95% of its steady state set value.

### Inrush Current

Inrush current is the peak, instantaneous, input current measured and, occurs when the input voltage is first applied. For AC input voltages, the maximum peak value of inrush current will occur during the first half cycle of the applied AC voltage. This peak value decreases exponentially during subsequent cycles of AC voltage.

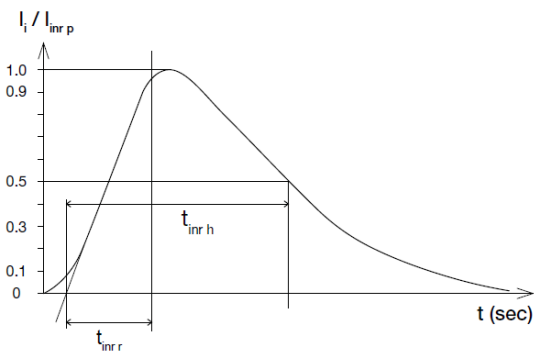

### Dynamic Response

The power supply output voltage will remain within  $\pm 10\%$  of its steady state value, when subjected to a dynamic load from 10% to 100% of its rated current.

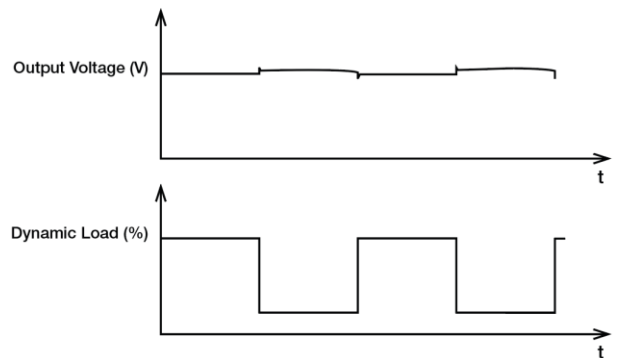

# DIN Pro Series DIN Rail Power Supply

## DRF-120W Series / DRF-□V120W1PBA

### Overload & Overcurrent Protections (Auto-recovery)

The power supply's Overload (OLP) and Overcurrent (OCP) Protections will be monitored by internal counter when output current ( $I_o$ ) is 125~205% of maximum rated load ( $I_o$  Max). After counter reaches the limit value (typically 5s), output current will be limited to 150% typ. (refer to ① below) and output voltage ( $V_o$ ) will start to droop. Once  $V_o$  is below approximately area, the power supply will start to operate in "Hiccup mode" as described in short circuit protection. The power supply will recover once the fault condition due to OLP or OCP is removed, then  $I_o$  is back within its specified limits.

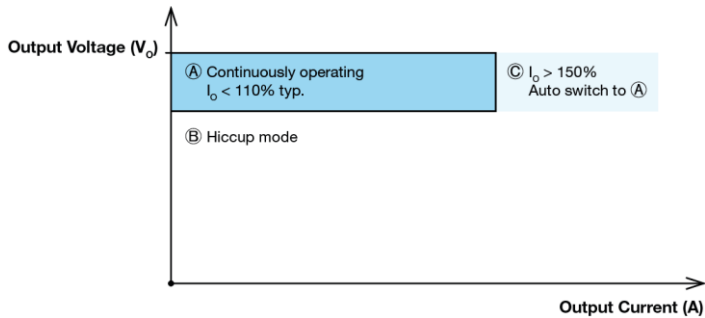

### Overvoltage Protection (Auto-recovery)

The power supply's overvoltage circuit will be activated when its internal feedback circuit fails. The output voltage shall not exceed its specifications defined on Page 4 under "Protections".

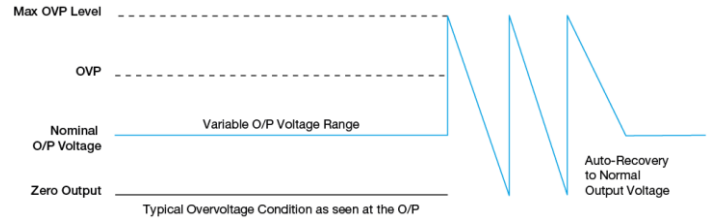

### Short Circuit Protection (Auto-Recovery)

The power supply's output Short Circuit Protection function also provides protection against short circuits. When a short circuit is applied, the output current will operate in "Hiccup mode". The power supply will return to normal operation after the short circuit is removed.

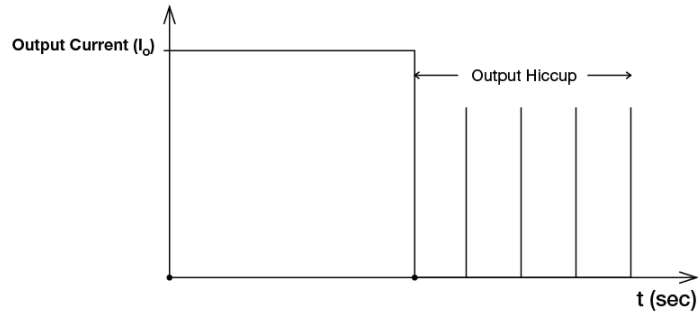

### Over Temperature Protection (Auto-recovery)

As described in load de-rating section, the power supply also has Over Temperature Protection (OTP). In the event of a higher operating temperature at 100% load; or, when the operating temperature is beyond what is recommended in the de-rating graph, the OTP circuit will be activated. When activated, power supply will latch off, until the surrounding air temperature drops to its normal operating temperature or the load is reduced as recommended in the de-rating graph. Removal/re-application of input AC voltage will then be required in order to restart.

# DIN Pro Series DIN Rail Power Supply

## DRF-120W Series / DRF-□V120W1PBA

### Operating Connection

#### DC Input Operation

- DC input voltage range 100-400 Vdc

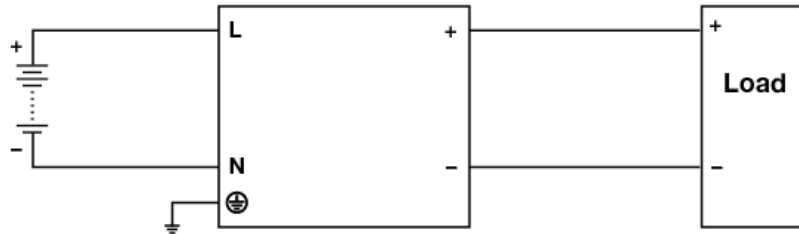

Fig. 5 DC Input Operation Connection Diagram

#### Step 1.

Use a battery or similar DC source.

#### Step 2.

Connect +pole to L and -pole to N.

#### Step 3.

Connect the PE terminal to an earth wire or to the machine ground.

### Others

#### Attention

Delta provides all information in the datasheets on an "AS IS" basis and does not offer any kind of warranty through the information for using the product. In the event of any discrepancy between the information in the catalog and datasheets, the datasheets shall prevail (please refer to [PSU.deltaww.com](http://PSU.deltaww.com) for the latest datasheets information). Delta shall have no liability of indemnification for any claim or action arising from any error for the provided information in the datasheets. Customer shall take its responsibility for evaluation of using the product before placing an order with Delta.

Delta reserves the right to make changes to the information described in the datasheets without notice.

### Manufacturer and Authorized Representatives Information

#### Manufacturer

##### Thailand

Delta Electronics (Thailand) PCL.  
909 Pattana 1 Rd., Muang, Samutprakarn, 10280 Thailand

##### Taiwan

Delta Electronics, Inc.  
3 Tungyuan Road, Chungli Industrial Zone, Taoyuan County  
32063, Taiwan

#### Authorized Representatives

##### The Netherlands

Delta Greentech (Netherlands) B.V.  
Zandsteen 15, 2132 MZ Hoofddorp, The Netherlands

##### United Kingdom

Delta Electronics Europe Limited  
1 Redwood Court, Peel Park Campus,  
East Kilbride, Glasgow, G74 5PF, United Kingdom